

# News from Rohde & Schwarz



Universal, portable combination of TV analyzer  
and spectrum analyzer

Test system for tire pressure sensors and signal  
analysis module for the automotive industry

New vector signal generators for production  
and all-purpose use

2005/II

186



**ROHDE & SCHWARZ**

The new TV Analyzer R&S®FSH3-TV combines spectrum analyzer functionality with the measurement capabilities of a TV test receiver, despite its extremely small size. Its compact design and low weight make it ideal for portable use in the installation, maintenance and servicing of TV transmitters and cable networks (page 46).



44 340

## MOBILE RADIO

### Coverage measurement systems

Radio Network Analyzer R&S®TSMU  
Unprecedented quality for mobile measurements in GSM networks..... 4

### Reference

ACCESSNET®-T: Russian railway – on the right track with TETRA ..... 8

### Radiocommunication testers

Universal Radio Communication Tester R&S®CMU 200  
CMU goes Internet: Testing data applications for WCDMA..... 10



The complex electronics in modern automobiles are increasing the need for test and measurement technology. Rohde & Schwarz presents a new system for testing tire pressure sensors, plus a new signal analysis module for multi-channel parallel data acquisition. A distinctive feature of this module is floating measurement technology – which is in demand especially in the automotive industry (pages 14 and 17).

## GENERAL PURPOSE

### Test systems

RF Test System R&S®TS 7810  
Testing tire pressure sensors in the automotive industry ..... 14  
Signal Analyzer Module R&S®TS-PAM for the R&S®CompactTSVP  
Floating, parallel signal analysis based on CompactPCI/PXI ..... 17

### Spectrum analyzers

Spectrum Analyzer R&S®FSL: A multipurpose instrument you won't want to miss ..... 20  
Spectrum Analyzers R&S®FSP / FSU / FSQ  
Phase noise testers of unparalleled quality..... 24

### Signal generators

Vector Signal Generator R&S®SMATE 200 A  
The rugged specialist for everyday use in production..... 27  
Vector Signal Generator R&S®SMJ 100 A  
The all-purpose generator that redefines the medium segment ..... 30

### Audio analyzers

Audio Analyzer R&S®UPV  
Advancing from an audio analyzer to a program-controlled measuring instrument .... 34

### Power meters

Power Meter R&S®NRP  
Fixed Noise: fast power measurement with defined accuracy..... 36



The Vector Signal Generators R&S®SMJ 100 A and R&S®SMATE 200 A, which are based on the tried-and-tested R&S®SMU 200 A, are the two newest members of the Rohde & Schwarz portfolio of generators. This portfolio now ideally covers virtually all conceivable requirements in R&D or in production (pages 27 and 30).



State-of-the-art technology makes it possible: The new multistandard Exciter R&S®Sx800 is housed in a box of only one height unit and includes complete signal processing functionality ranging from the video/audio input signal (analog TV) and the transport stream (digital TV) to standard-compliant RF output signals (page 41).



Outstanding technical parameters, an optimum cost/benefit ratio, extremely high reliability and ease of servicing distinguish the new air-cooled FM Transmitters R&S®NR8200, which cover the power range from 2.5 kW to 30 kW (page 44).

## EMC / FIELD STRENGTH

### Test systems

EMC Measurement Software R&S®EMC32-W+	
EMC measurements on mobile radio terminals .....	38

## BROADCASTING

### TV transmitters

Exciter R&S®Sx800: Multistandard exciter for ATV and DTV .....	41
--	----

### Sound transmitters

Family of VHF FM Transmitters R&S®NR8200	
Compact, air-cooled transmitters for 2.5 kW to 30 kW .....	44

### Analyzers

TV Analyzer R&S®FSH3-TV	
Universal, portable combination of TV analyzer and spectrum analyzer .....	46

### Monitoring systems

MPEG-2 Monitoring System R&S®DVM	
Video decoder, DVB-H analysis and other novelties .....	50

## COMMUNICATIONS SECURITY

### Crypto products

TopSec Encryption Units	
Secured communications for global players .....	53

## RADIOCOMMUNICATIONS

### Reference

Civil radiocommunications for Australian air traffic control .....	56
--	----

## MISCELLANEOUS

Newsgrams .....	58
-----------------	----

Published by Rohde & Schwarz GmbH & Co. KG · Mühldorfstrasse 15 · 81671 München  
 Support Center: Tel. (+49) 01805 124242 · E-mail: customersupport@rohde-schwarz.com  
 Fax (+49 89) 41 29-137 77 · Editor and layout: Ludwig Drexler, Redaktion – Technik (German)  
 English translation: Dept. 9UK7 · Photos: Rohde & Schwarz · Printed in Germany · Circulation (German, English, French, Russian and Chinese) 90 000 approx. 4 times a year · ISSN 0028-9108 · Supply free of charge through your nearest Rohde & Schwarz representative · Reproduction of extracts permitted if source is stated and copy sent to Rohde & Schwarz München.

R&S® is a registered trademark of Rohde & Schwarz GmbH & Co. KG. Trade names are trademarks of the owners. CDMA2000® is a registered trademark of Telecommunications Industry Association (TIA USA). The Bluetooth word mark and logos are owned by the Bluetooth SIG, Inc. and any use of such marks by Rohde & Schwarz is under license.





44 064/11

**FIG 1**  
The Radio Network Analyzer R&S®TSMU has made its mark with WCDMA network measurements. Fitted with a new option, it now also analyzes GSM networks.

## Radio Network Analyzer R&S®TSMU

# Unprecedented quality for mobile measurements in GSM networks

**The Radio Network Analyzer R&S®TSMU has set standards as a PN scanner for WCDMA networks (FIG 1). Equipped with the new option R&S®TSMU-K13, it can now also analyze the receive conditions in GSM networks in unprecedented quality by identifying the base stations in the network and measuring their signal propagation – at maximum speed during the test drive.**

**GSM network optimization has become more sophisticated than ever**

Interference analysis in GSM mobile radio networks has always played a key role in network optimization. Since obtaining usable results is still a highly intricate process [1, 2], many network operators take a closer look only at particularly critical areas.

Introducing the new mobile radio standards (E)GPRS and WCDMA has considerably enhanced the requirements placed on GSM network quality. These technologies call for a substantially higher signal-to-noise ratio across the entire network than was previously necessary. The reason for this is the new modulation mode with (E)GPRS and the

critical 3G/2G handover scenarios at the WCDMA network coverage boundaries.

GSM interferences are caused by other base stations transmitting on the same or on adjacent channels (co-channel or adjacent channel interference). This frequency re-use is system-inherent in GSM networks and continuously optimized by the network operators. However, the data for the planning and simulation tools for these tasks needs to be continuously adapted to the actual conditions. For this purpose, you need an instrument that provides full-coverage GSM network information.

## New solution with a tried-and-tested platform

For its Radio Network Analyzer R&S®TSMU [3, 4], which has already set standards in WCDMA network measurements, Rohde & Schwarz has developed an application that dwarfs all known solutions for GSM network scanners – the GSM Network Scanner R&S®TSMU-K13 (FIG 2). This new option expands the R&S®TSMU functions, making it possible for the first time to determine the data of WCDMA, CDMA2000® and GSM mobile radio networks in all bands as part of test drives with just a single instrument. Interconnecting several R&S®TSMU analyzers even allows you to perform simultaneous measurements in different mobile radio standards.

## How to measure

The scenario becomes tricky whenever several broadcast control channels (BCCH) or traffic channels (TCH) coincide on an RF channel or on adjacent channels. It is important to find out where the exact locations are and which base stations contribute to interference, or might contribute to interference after the channel configuration has been optimized.

For this purpose, the GSM network scanner detects BCCH signals and their power on all selected GSM channels at an unrivaled high scan rate. Since each channel can receive several BCCH signals, the scanner demodulates the station identifications included in these signals and assigns them to the individual base stations. The interference caused by TCH channels depends on the network load, which means it can be indirectly determined by the BCCH

## Superior performance

- ◆ Compact, user-friendly, robust, low power consumption; can also be used indoors in combination with the R&S®TSMU-Z3 backpack solution
- ◆ Measurement preparations at a minimum – plug & play
- ◆ Quasi-parallel measurements in all GSM networks, without affecting the network (as is the case with test mobile phones and test transmitters), also across national borders
- ◆ High drive speed possible; also suitable for unattended applications (autonomous systems)
- ◆ Automatic detection of GSM system information types 1 and 3
- ◆ Positive identification of the base stations via cell identity (CI) and location area information (LAI)
- ◆ Power measurement – high level accuracy due to calibration
- ◆ Best server analysis for the BCCH

**FIG 2 Compact and robust:** Equipped with the R&S®TSMU-K13 GSM network scanner option, the Radio Network Analyzer R&S®TSMU can determine the data of WCDMA, CDMA2000® and GSM mobile radio networks in all bands.



## Extensive measurement results

- ◆ Absolute radio frequency channel number (ARFCN)
- ◆ Channel power: BCCH power, S/N, maximum TCH power (in dBm)
- ◆ Network color code (NCC)
- ◆ Base station color code (BCC)
- ◆ Cell identity (CI)
- ◆ Location area code (LAC)
- ◆ Mobile network code (MNC)
- ◆ Mobile country code (MCC)
- ◆ Measurement time (40 ns resolution)
- ◆ GSM frame number (absolute and relative)
- ◆ TDMA frame shifting
- ◆ Date and time, GPS information
- ◆ Further base station information (assigned by the central base station database)

44064/7b

- ▶ power measurement results. TCH transmission rate information plus power control statistics ensure that the time-dependent character of a TCH interference is taken into account in the optimization process.

The R&S®TSMU measures the code power of the extended training sequence of the synchronization channel (SCH) for high S/N ratios ( $S/N > -5$  dB) as well as the code power of the entire SCH for lower S/N ratios. With Gaussian noise, the measurement works if the S/N is  $-13$  dB or higher; with GSM-internal noise signals, it works if the C/I is  $-20$  dB or higher. Every 125 ms, the instrument intercepts a maximum of ten adjacent GSM channels (2 MHz), so that the overall measurement rate can be up to 80 channels per second (FIG 3).

The information thus obtained permits further analyses. Based on this measured data, Coverage Measurement Software R&S®ROMES [5] derives a best server evaluation for the GSM networks and outputs it in the Top-N display (which has proven itself with the WCDMA standard) in the user interface and in maps (FIG 4). In this way, network operators receive full-coverage, high-resolution information about the serving cells that are currently most powerful in their areas.

In addition, the software generates a base station list from the data. This list includes cell identity, MCC, MNC, LAC as well as a rough transmitter location, which is determined by means of a location function after the measurement has been completed. Existing base station lists that may be obsolete can thus be updated in the system, or completely new lists can be generated. This is especially important in border areas where transmitters in the neighboring country may cause interference in an operator's network.

## Test drives with R&S®ROMES

The flexible and powerful R&S®ROMES coverage measurement software includes the GSM network scanner application. It is the basis for measurement sequences, data acquisition and storage as well as for analyzing and visualizing test drives. The software supports all major mobile radio standards. Its high modularity allows a large number of instruments, including – and especially – different technologies (e.g. receivers/scanners, test mobile phones and navigation equipment) to be controlled simultaneously. In addition to pure measurement data acquisition, R&S®ROMES also offers numerous analysis functions such as quality of service (QoS) measurements or the combined analysis of 2G/3G networks.

## Post-processing with MEDAS

The company Cosiro offers a powerful, geographic data warehouse solution called MEDAS, which ensures consistent central post-processing of large volumes of spread measurement data from 2G, 2.5G and 3G networks. MEDAS is a tool for a wide range of functions, such as planning networks, evaluating market launches, measuring network performance, evaluating and optimizing radio links, analyzing service quality plus evaluating the quality of nationwide networks.

MEDAS also handles the difficult interference analysis for GSM networks and clearly displays the processed results for entire countries. Field trials show that the combined use of the GSM network scanner with MEDAS drastically cuts the number of disconnections in GSM networks.

Option R&S®TSMU-K13 provides the measurement data in an open format, making it possible to use also other tools for the post-processing or frequency planning for measurement processing.

## Future-oriented with Rohde & Schwarz

The future of measurement data acquisition for GSM network optimization lies in fast, efficient and cost-effective solutions such as the new R&S®TSMU-K13 GSM network scanner option from Rohde & Schwarz. The Radio Network Analyzer R&S®TSMU is an unparalleled base instrument for these as well as numerous other software applications in mobile radio. Users of the R&S®TSMU can rest assured that working with the world's best measuring instrument in network optimization is future-proof.

R&S®TSMU analyzers already supplied can be retrofitted with the new option at all Rohde & Schwarz service centers.

Wolf Dietrich Seidl

More information and data sheets at  
[www.rohde-schwarz.com](http://www.rohde-schwarz.com)  
 (search term: TSMU)

### REFERENCES

- [1] Mobile interference measurement in GSM networks. News from Rohde & Schwarz (1998), No. 160, pp 24–25
- [2] GSM Interference Analyzer ROGER (R&S®TS9958): Full coverage, mobile and automatic measurement of GSM interference. News from Rohde & Schwarz (2000), No. 168, pp 4–6
- [3] PN Scanner R&S®TS5K51C: Turbo for UMTS network optimization. News from Rohde & Schwarz (2002), No. 176, pp 4–9
- [4] Radio Network Analyzer R&S®TSMU: Performance giant in compact format sets new standards. News from Rohde & Schwarz (2003) No. 180, pp 4–7
- [5] Coverage Measurement Software R&S®ROMES3: Acquisition, analysis and visualization of data in coverage measurements. News from Rohde & Schwarz (2000), No. 166, pp 29–32



Scan No.	T 1970 [s]	Latitude	Longitude	ARFCN	Pow [dBm]	NCC	BCC	CI	LAC	MNC	MCC	ST3 Source
509	1099597054	49.810.966	14.347.830	6	-81.5	3	5	57963	33542	4	262	BT list
509	1099597054	49.810.947	14.347.733	12	-72.0	3	0	22657	33543	4	262	BT list
509	1099597054	49.810.947	14.347.733	36	-73.3	3	1	23914	33542	4	262	BT list
509	1099597054	49.810.966	14.347.830	48	-79.6	3	4	48307	33543	4	262	BT list
509	1099597054	49.811.190	14.348.923	96	-74.7	3	2	23916	33542	4	262	BT list
509	1099597054	49.811.396	14.349.938	96	-92.3	4	2	13347	5010	7	232	T scan
509	1099597054	49.810.966	14.347.830	98	-74.3	3	1	9439	33542	4	262	BT list
509	1099597054	49.811.190	14.348.923	98	-73.1	3	5	49349	33543	4	262	BT list

FIG 3 List section with measurement results provided by the GSM network scanner.

### Condensed data of the R&S®TSMU-K13

Supported standards	GSM 450 / 750 / 850 / 900 / 1800 / 1900 and GSM-R/E
Code power measurement of the extended SCH training sequence of the entire SCH with GSM interferer	S/N >= 5 dB S/N >= 13 dB C/I >= 20 dB
Level measurement uncertainty (with GSM interferer C/I >= 20 dB)	±1 dB (S/N > 2 dB) ±3 dB (S/N >= 13 dB)
Max. measurement rate	80 channel/s
Dynamic range	-112 dBm to -20 dBm
Adjacent channel suppression	70 dB (sinusoidal carrier)
Probability of success for BCH decoding	50% (S/N >= -0.5 dB) 80% (S/N > 0.5 dB) 95% (S/N > 2.5 dB) 98% (S/N > 3.5 dB)

### Special assets

- ◆ Integrated in R&S®ROMES: universal software platform, user-friendly operation, online display, map display
- ◆ Open format for further processing of measured data
- ◆ A single instrument for WCDMA, CDMA2000®, GSM and analog power measurements
- ◆ New features by means of easy software update
- ◆ Provides all the data required by frequency planning tools
- ◆ Optimization of 3G/2G handover scenarios
- ◆ Online neighborhood analysis with GSM and WCDMA test mobile phones and WCDMA network scanner
- ◆ Patented Rohde & Schwarz method

FIG 4: GSM measurement using a GSM network scanner and test mobile phone near a national border.

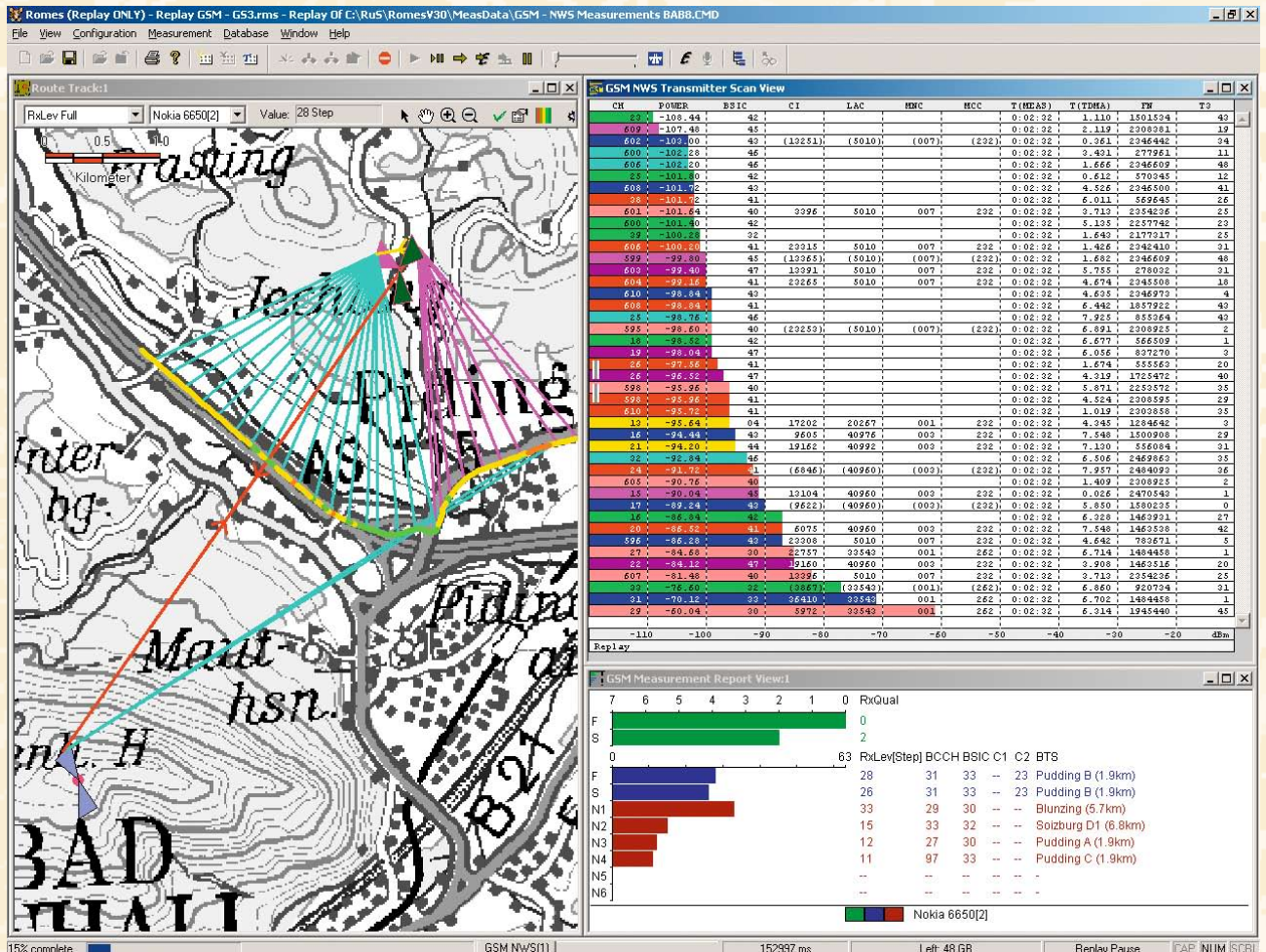

TETRA Mobile Radio System *ACCESSNET*<sup>®-T</sup>

## Russian railway – on the right track with TETRA

**TETRA radio systems are enjoying undiminished success all over the world. The reasons are obvious, ranging from the systems' open, ETSI-certified standard and their wide support by independent manufacturers to their versatile applications for heterogeneous user groups. And these are just some of the arguments in favor of *ACCESSNET*<sup>®-T</sup> TETRA radio systems from R&S BICK Mobilfunk, which have proven themselves worldwide in diverse applications for years. The Russian railway management also decided in favor of**

***ACCESSNET*<sup>®-T</sup>.**

### A success story ...

In the third quarter of 2002, R&S BICK Mobilfunk GmbH furnished the Russian railway management with an *ACCESSNET*<sup>®-T</sup> TETRA radio system to provide radio coverage for the railway lines around Yekaterinburg (formerly Sverdlovsk). A local company installed the system between late 2002 and early 2003. Once the installation was completed, R&S BICK Mobilfunk configured and tested the system, which started its trial operation in the spring of 2003. Already in the summer of the same year, the system was handed over to the Yekaterinburg railway management and started actual operation.

At that time, the *ACCESSNET*<sup>®-T</sup> radio system covered roughly 180 km (112 miles) of railway lines plus the entire railway works of the Yekaterinburg railway management. The system provided radiotelephony for the railway, service and maintenance staff and controlled railway traffic.

During its initial stage, the radio system consisted of two R&S<sup>®</sup>DMX-521 exchanges and sixteen R&S<sup>®</sup>DTX-500 base stations (FIG). Sixteen R&S<sup>®</sup>REM-500 dispatcher consoles (not shown in FIG) served as cost-efficient dispatcher stations. The R&S<sup>®</sup>NMS-500 network management system, including the clients for subscriber management and network configuration, monitored network operation. TETRA radios from different manufacturers were deployed in the network, proving that *ACCESSNET*<sup>®-T</sup> supports diverse terminals.

Four base stations were all connected in series, with the first and the last station connected with one of the two exchanges, forming four circle structures. These were additionally complemented by a direct line between the exchanges. Even if a communications line failed, the functionality of the entire system remained unaffected. The individual network elements were connected with each other via an optical network.

### ... to be continued

In November 2004, after the TETRA radio system had been successfully operating for about one and a half years, the Russian railway management decided to cover yet another railway line of the Yekaterinburg railway management with the TETRA radio system. One R&S<sup>®</sup>DMX-582 TETRA exchange and ten R&S<sup>®</sup>DIB-540 TETRA digital indoor base stations are part of the delivery package. The exchange comes configured in such a way as to provide capacity for up to 80 base stations. A multiposition R&S<sup>®</sup>TRD-500 control center will also be supplied as part of the new contract; the R&S<sup>®</sup>TRD-500 consists of one server and two clients and is connected to the ACAPI application interface of *ACCESSNET*<sup>®-T</sup>. The control center is connected to the exchange via a LAN. Voice communications are handled via a voice-over-IP connection.

The equipment supplied also includes the R&S<sup>®</sup>APS-500 train application server; for communication purposes, it now allows the staff to use train numbers as addresses instead of individual dialing numbers, as is usual. To place a



call, the staff uses the respective train number as the call address, which is then displayed in the radios and the control center. The advantage of this procedure is obvious: The operating staff no longer needs to know the dialing numbers of the TETRA terminals because these numbers are assigned dynamically. This feature helps avoid misunderstandings or errors.

Using an ACAPI interface is highly beneficial because, in addition to the control center, customized applications can also be connected to the *ACCESSNET*®-T radio system.

The system was supplied in December 2004 and is currently being installed. The handover and start of actual operation are scheduled for the second quarter of 2005. As a result of this expansion, well over 400 km (249 miles) of railway lines, plus the railway territory and the railway works of the Yekaterinburg railway management, will be covered by TETRA radio.

### And there's more to come

The radio system operators deliberately designed the second stage in such a way that further expansion would pose no problems: Just recently, R&S BICK Mobilfunk GmbH was commissioned by the Yekaterinburg railway management to supply ten additional base stations to provide radio coverage for yet another railway line.

Harald Haage

Basic infrastructure of the *ACCESSNET*®-T TETRA radio system of the Yekaterinburg railway management during the initial phase in 2003.

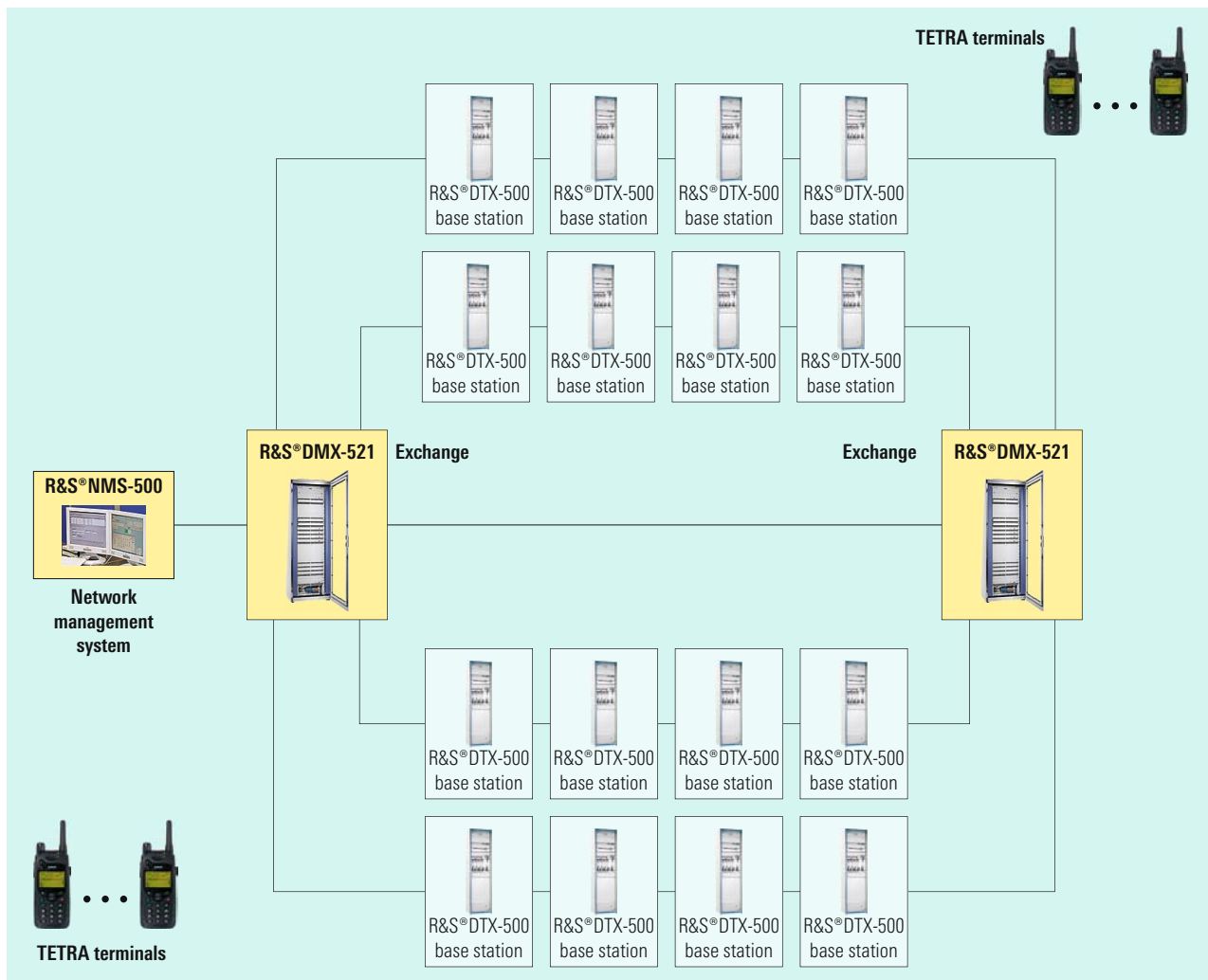

## Universal Radio Communication Tester R&amp;S®CMU 200

# CMU goes Internet: Testing data applications for WCDMA

In addition to testing data applications for CDMA2000® [1] and (E)GPRS [2], the R&S®CMU 200 can now also test these applications on WCDMA mobile phones. The highly successful mobile radio tester, which was originally designed as a pure RF tester, now enables additional user groups to test video telephony and data applications.

## Appealing compact solution

Both developing and providing data applications for mobile radio present a multitude of new challenges. Most applications in data communications are based on the Internet protocol (IP), which in turn is based on the client-server principle. This means that a client uses a mobile phone to request services that are provided by a server in the communications network. The software for these applications is usually developed on PCs; after its implementation and extensive computer simulations, the software is ported to the mobile phone. To perform further tests on the mobile phone itself, a public mobile radio network or the simulation of such a network is required.

Up to now, radio networks could usually be simulated only with the aid of complex setups. This is remedied by the R&S®CMU 200, which is a very interesting alternative for such tasks. Due to the extensive possible settings it offers, tests can also be performed on frequency bands, for example, that are not necessarily part of an available public radio network.

Before communications services can be launched on the market, network operators must subject them to interoperability tests to ensure that they operate smoothly. With the multimedia message service (MMS), for example, the correct exchange of messages with the server implementation in the network

FIG 1  
WCDMA application test setup and protocol stack.

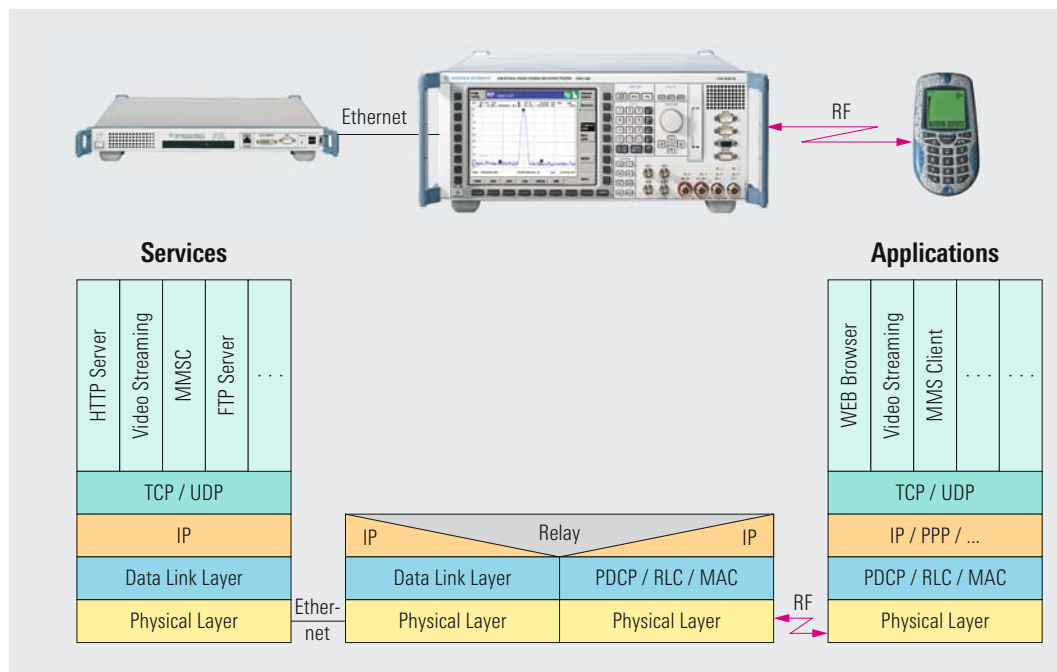

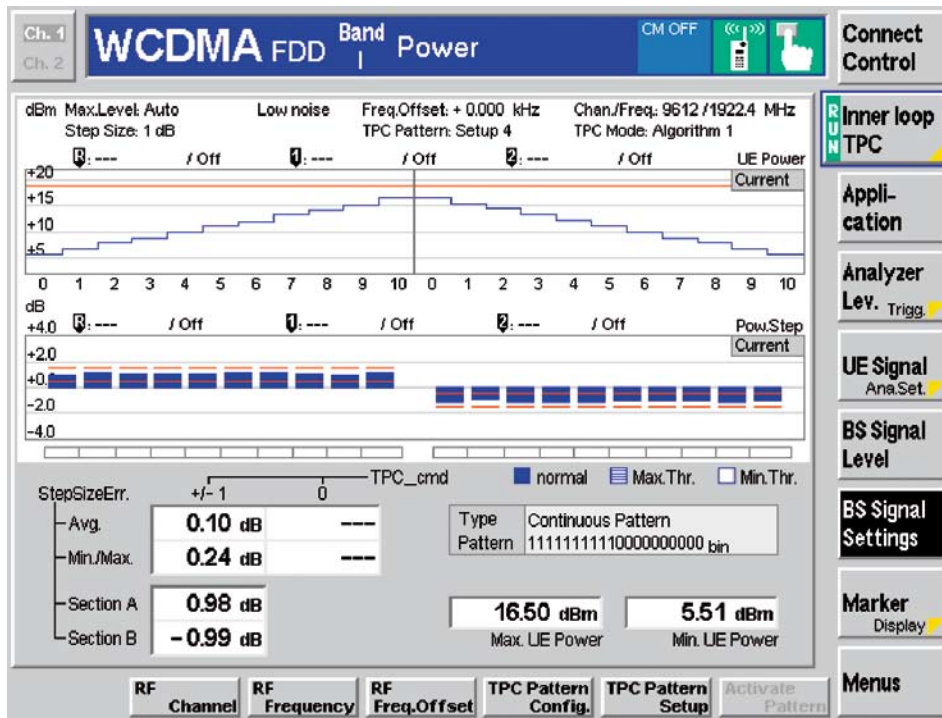

FIG 2 Example of a transmitter measurement.

or between mobile phones from different manufacturers is checked. Moreover, making objective comparisons under user-definable and randomly reproducible operating and test conditions is another pivotal function this target group needs.

### Test setup

Application test setups basically consist of a mobile phone, the R&S®CMU 200 and a PC (FIG 1). The mobile radio tester, which is connected to the mobile phone via the radio interface, simulates the mobile radio network. Via an Ethernet connection, it accesses the IP-based computer world, which can be either a local area network (LAN), the Internet or, at its simplest, a controller, where the servers providing the communications services can be accessed. The user usually accesses these services from the mobile phone via mobile originated

calls. The R&S®CMU 200 bridges the gap between wired data communications and radiocommunications across various protocol layers.

### Versatile test scenarios

Go/NoGo tests start an application on the mobile phone and test the operation from the user's viewpoint. These tests differ from RF measurements performed with the R&S®CMU 200 by covering the entire operating system of a phone and subjecting it to the appropriate stress. After an application passes this basic test, performance measurements are usually carried out; their aim is to analyze the achievable data transmission rates in the downlink and the uplink.

Another noteworthy criterion that helps determine the practical value of mobile phones is their operating time with rechargeable batteries. To minimize a

phone's power consumption, you need to measure the consumption while an application is active so that you can find out more about possible optimization procedures. If required, the mobile radio tester simultaneously records detailed information about the processed protocol layers in a log file, which is then available for future evaluation and analysis.

Interaction tests analyze how different, simultaneously active applications on a mobile phone affect each other. These tests analyze, for example, what will happen if an SMS arrives while a video is being downloaded and the calendar function is outputting an alarm.

Interoperability tests check whether mobile phones function smoothly within a network, for example when interacting with the network operator's MMS server, or when two phones from different manufacturers interact with each other. In the simplest case, just one phone is used in the loop-back mode to perform a combined transmission/reception test.

### Settings and measurement results

To configure the WCDMA radio network for application tests, the R&S®CMU 200 parameter settings known from the RF measurements can be used and dynamically adjusted during testing. Changing the channel numbers triggers an intracell handover, for example. Since a reduced transmit level increases the bit error probability at the receiver end, an application function on a mobile phone can also be tested under adverse receive conditions. If the application test is performed in compressed mode, the mobile phone is subjected to additional stress, which allows you to check the quality of the UE report transmitted from the mobile phone to the tester. While an application is running on the mobile



▶ phone, the known transmitter measurements such as power, code domain power and modulation can still be performed (FIG 2). The block error ratio (BLER) determined by the R&S®CMU 200 is used to evaluate the receiver in the mobile phone.

In combination with an additional fading simulator such as the R&S®ABFS, the function of an application can be simulated at different speeds in vehicles and in varying environments.

## Remote control and automation

To remote-control the R&S®CMU 200 during application tests, an IEC/IEEE bus interface is available; it can be used, for example, to automatically obtain measurement results and measurement values – a prerequisite for program-controlled sequences. Such automatically running tests can be repeated at any time and as often as necessary without staff intervention, thus helping to increase the system's efficiency.

## Protocol analysis

After the software has been ported to the mobile phone, users often want to record protocols to optimize internal processes or to perform an error analysis that may be necessary. The R&S®CMU-Z46 WCDMA message analyzer and recorder option allows all universal terrestrial radio access network (UTRAN) protocol layers to be recorded, which can then be used for more detailed analysis (FIG 3). This powerful tool permits in-depth analyses, including transport layer analyses.

FIG 3 The R&S®CMU-Z46 WCDMA message analyzer and recorder option records all UTRAN protocol layers.

The screenshot displays the Message Analyzer software interface with a menu bar (File, Edit, View, Project, Tools, Help) and a toolbar. The main window shows a table of recorded messages with columns for No., Time, RRC, RLC, MAC, PHY, and Auxiliary. The data is as follows:

No.	Time	RRC	RLC	MAC	PHY	Auxiliary
252	05:27:20:51		RRConnectionSetupCon			RB = 2:AM+DCCH
254	05:27:20:524			(MAC DCCH Data)		RB = 2:AM+DCCH;
255	05:27:20:563			(MAC DCCH Status)		RB = 2:AM+DCCH;
256	05:27:20:565			RLC AM PDU (MAC DCCH Data)		RB = 2:AM+DCCH; D/C
257	05:27:20:572				(PHY DCH-DL Data)	NrTrBlk = 1; CFN = 232;
258	05:27:20:781				(PHY DCH-UL Data)	NrTrBlk = 1; CFN = 244;
259	05:27:20:781			RLC AM PDU (MAC DCCH Data)		RB = 3:AM+DCCH high;
260	05:27:20:821				(PHY DCH-UL Data)	NrTrBlk = 1; CFN = 248;
261	05:27:20:821			RLC AM PDU (MAC DCCH Data)		RB = 3:AM+DCCH high;
262	05:27:20:861				(PHY DCH-UL Data)	NrTrBlk = 1; CFN = 252;
263	05:27:20:861			RLC AM PDU (MAC DCCH Data)		RB = 3:AM+DCCH high;
264	05:27:20:862			InitialDirectTransfer (RLC AM Ar		RB = 3:AM+DCCH high;
265	05:27:20:866	(RRC GC NAS Establish)				
266	05:27:20:867	MM Location Updating Reques				IdType = TMSI/P-TMSI;
267	05:27:20:868	MM Identity Request (RRC DC				IdType = IMSI;
268	05:27:20:869			DownlinkDirectTransfer (RLC AM A		RB = 3:AM+DCCH high;
269	05:27:20:884			(MAC DCCH Data)		RB = 3:AM+DCCH high;
270	05:27:20:924			(MAC DCCH Status)		RB = 3:AM+DCCH high;
271	05:27:20:925			RLC AM PDU (MAC DCCH Data)		RB = 3:AM+DCCH high;
272	05:27:20:932				(PHY DCH-DL Data)	NrTrBlk = 1; CFN = 12;
273	05:27:20:964			(MAC DCCH Status)		RB = 3:AM+DCCH high;
274	05:27:20:965			RLC AM PDU (MAC DCCH Data)		RB = 3:AM+DCCH high;

Below the table, there is a tree view showing RLC Routing information for one or more RBs = (0) and other parameters like Cell/Ue indicator, Cell/UE Identity indicator, User Equipment Identity, Radio Bearer Selector, and RadioBearerId.

At the bottom, there are sections for "Errors/Warnings", "Search results", and "Parent/Children". The "Predecessors of selected message" and "Successors of selected message" sections are currently empty.

The status bar at the bottom indicates "Offline Mode".

## TCP/IP services

The clients on the mobile phone require suitable servers at the controller end as a counterpart for application tests. The R&S®CMU-K96 WCDMA application testing option allows IP-based data applications to be tested on a mobile phone; in addition, it includes several TCP/IP servers, for example an HTTP server, which allows you to start a web browser on a mobile phone. Another server is the MMS center (MMSC) with basic functionality, which can be used to test the transmission and reception of multimedia messages on a mobile phone.

The R&S®CRTU-AA01 option helps develop or test the MMS features on a mobile phone; this option is a powerful development tool for analyzing and synthesizing MMS and is equipped with an MMSC plus integrated viewer, parser and composer.

## Test cases relevant for certification

To ensure a uniform MMS standard, test cases that verify the correct reproduction of various multimedia content [3] were defined on behalf of the Global Certification Forum (GCF). The application test on the R&S®CMU 200 can be further expanded by the R&S®CRTU-AC01 MMSC test cases option with validated test cases. These need to be certified for all mobile phones that support MMS (FIG 4).

## Video telephony

In all likelihood, video telephony is the most spectacular new WCDMA application. It is unique in that it is circuit-switched, and not IP-based like the previously described applications. The WCDMA firmware checks this function-

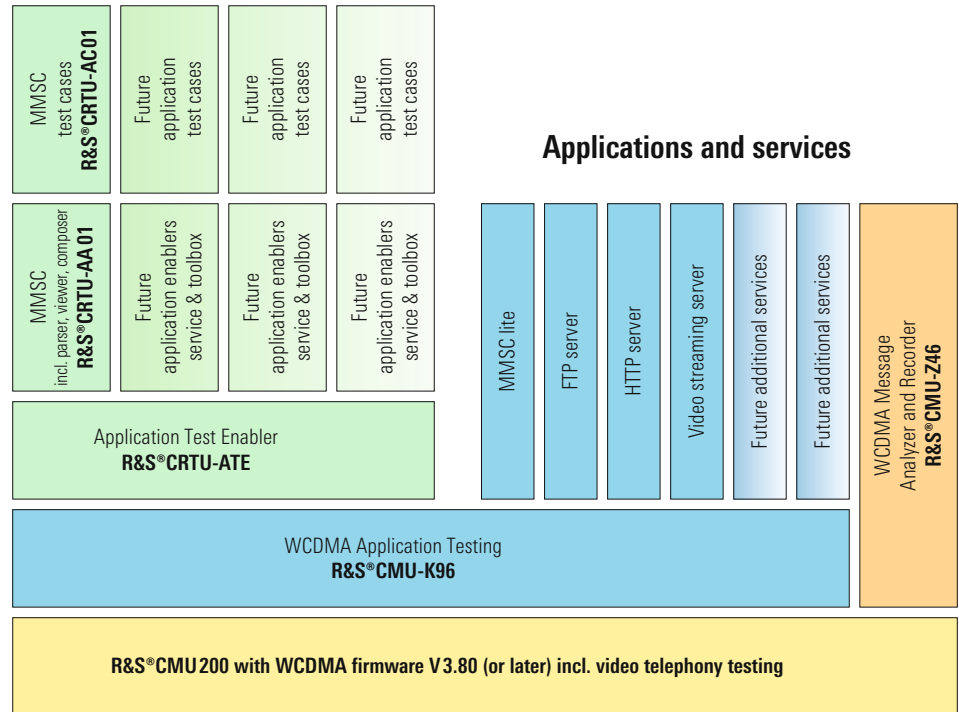

FIG 4 Overview of the range of options to complement the R&S®CMU200 for testing WCDMA data applications.

ality without requiring optional extensions. The test is performed in echo mode, where the transmission and reception of video and audio signals can be checked with just one mobile phone. The video telephony signals transmitted by the phone to the R&S®CMU 200 are looped back from the radio tester and displayed by the phone as would-be video and audio signals of a called station.

## Future prospects

The application test is the latest addition to radiocommunications testing and sure to gain increasing importance over the next few years. Rohde & Schwarz will continue to enhance the functional scope of the R&S®CMU 200's current test functions to match market requirements. The next steps to be taken include the expansion to high speed

downlink packet access (HSDPA) and, once a uniform worldwide standard has been specified, to test cases for push to talk over cellular (PoC).

Thomas A. Kneidel

More information and data sheet at  
[www.rohde-schwarz.com](http://www.rohde-schwarz.com)  
 (search term: CMU200)

### REFERENCES

- [1] R&S®CMU 200: Testing CDMA2000® data applications. News from Rohde & Schwarz (2004) No. 182, pp 11–13
- [2] R&S®CMU 200: Versatile application tests in (E)GPRS mobile radio. News from Rohde & Schwarz (2004) No. 184, pp 10–13
- [3] Protocol Tester R&S®CRTU-G/-W: MMS tests on multimedia mobile phones. News from Rohde & Schwarz (2005) No. 185, pp 4–6

## RF Test System R&amp;S®TS7810

# Testing tire pressure sensors in the automotive industry

The RF Test System R&S®TS7810 is designed especially for the fast growing market of tire pressure sensors. By using standard equipment such as the Spectrum Analyzer R&S®FSP3 or the Open Test Platform R&S®CompactTSVP, the R&S®TS7810 can be quickly adapted to meet project-specific requirements. For use in production, development and quality assurance, Rohde & Schwarz provides both the turnkey system and individual system components.

## Tire pressure sensors are becoming standard

In the recent years, the safety of automobiles has continuously increased. Nevertheless, in 30% of the serious accidents that occur due to technical defects of the vehicle, the accident cause can be attributed to the tires. A number of tragic accidents in the USA, for example, happened as a result of a specific tire model having too low a pressure. In the coming years, in the USA all vehicles up to five tons must therefore be equipped with a tire pressure monitoring system (TPMS).

Primarily, two different methods are currently used for measuring tire pressure: An indirect measuring system that uses ABS sensors, and a direct measuring system that uses sensors with radio interface built into the tire. The indirect measuring system uses the information of the ABS sensors for calculation and

calculates changes in tire pressure from the different tire speeds. This system can be implemented economically but has the disadvantage that tire speed cannot be measured when the vehicle stops or when the pressure of two tires drops simultaneously. Direct measuring systems with sensor technology are thus expected to gain the upper hand on the market.

In addition to tire pressure, tire temperature and acceleration are also transmitted to the central control unit in the vehicle. The tire pressure sensor is a potted, LSI module and basically contains a sensor chip with  $\mu$ -controller and an ISM transmitter that generates the RF signal. It is powered by a lithium battery with a lifetime of up to 100 000 km. There are also ways to supply power by means of the tire vibration energy or by using an external magnetic field via a coil within the wheel housing. The European Union already supports this tech-



FIG 1 The compact R&S®TS7810 can be easily integrated into production lines (here with generator for optional receiver measurements).





nology with research programs, and tire pressure sensors are expected to become standard equipment in all vehicles over the next ten years.

## Versatile and compact

With the R&S®TS 7810, Rohde & Schwarz now provides an all-in-one test solution for the fast growing TPMS market (FIG 1).

This test system includes the CompactPCI/PXI-based Open Test Platform R&S®CompactTSVP [1], the R&S®GTSL system software, the Spectrum Analyzer R&S®FSP 3, the Shielded RF Test Fixture R&S®TS 7110 [2] as well as customer-specific test sequence adaptations.

A pressure-proof chamber simulates tire pressure inside the R&S®TS 7110 test fixture. Different pressure values can be set by means of a programmable pressure control unit. Since the R&S®TS 7110 is RF-shielded, several test systems can be operated in parallel without affecting each other.

## Which standard?

There are a number of license-free radio bands (ISM: industrial, scientific, medical) in the frequency range from 100 MHz to 3 GHz. They are used for transmitting short data packets. Europe transmits in the 433 MHz and 868 MHz bands while the USA and Japan use the 315 MHz and 915 MHz bands. The 2.4 GHz band is freely accessible worldwide.

The Spectrum Analyzer R&S®FSP 3 covers this wide frequency range. By adding the optional FM Measurement Demodulator R&S®FS-K7, the R&S®FSP 3 also measures the different modulation modes such as on-off keying (OOK), amplitude shift keying (ASK) and frequency shift keying (FSK).

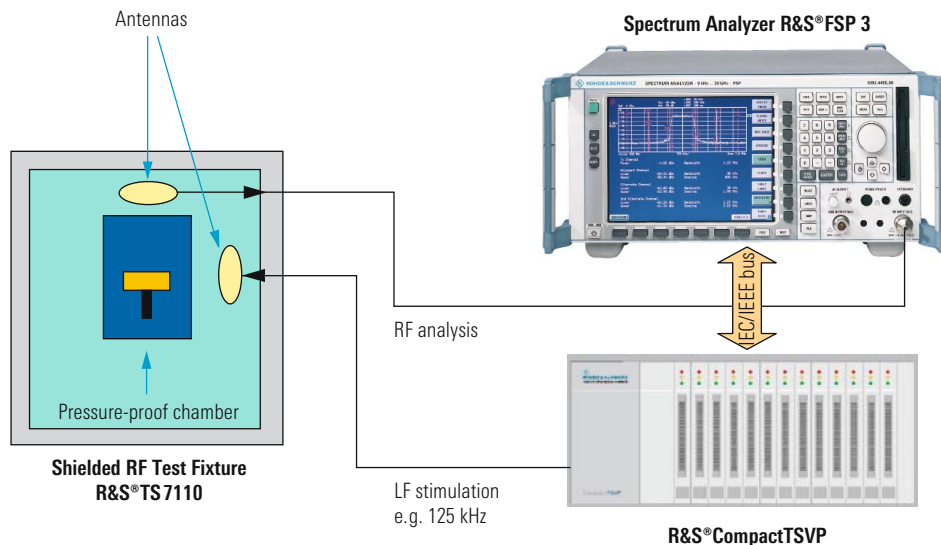

FIG 2 Stimulation and measurement of a tire pressure sensor.

TPMS receiver modules can be easily tested simply by expanding the R&S®TS 7810 by a signal generator. The RF test system thus covers applications not only in the automotive industry but also in industrial and consumer electronics.

## Comprehensive tests

The automotive industry requires its suppliers to perform extensive tests including documentation of the test results for each single part. Only an automatic test system such as the R&S®TS 7810 can meet this requirement.

The R&S®GTSL system software, which controls all test runs, issues the start command for a measurement. The software's open architecture makes it easy to integrate the R&S®TS 7810 into fully automatic production lines. The Open Test Platform R&S®CompactTSVP, which was specially designed for testing modern automotive electronics, then generates a 125 kHz LF data telegram that stimulates the tire pressure sensor in the test fixture (FIG 2). If necessary, you can expand the R&S®CompactTSVP

with additional CompactPCI/PXI measurement and control cards for communicating with the production cell or for programming  $\mu$ -controllers on printed boards, for example.

An antenna module with an amplifier in the R&S®TS 7110 transfers the transmitted data to the Spectrum Analyzer R&S®FSP 3, which measures the most important RF parameters such as RF power, RF frequency offset and frequency deviation in one cycle and demodulates the data telegram (FIG 3). The R&S®FSP 3 then transfers the digitized data telegram content to the controller, where the system software analyzes the data telegram content together with the TestStand® sequencer from National Instruments. Contents such as pressure or temperature are displayed clearly and concisely.

If the vehicle is moving, each tire pressure sensor transmits three to five data packets per minute with a period of approx. 10 ms and makes variable pauses of about 100 ms between each packet (FIG 4). The individual data telegrams of the four tires can superimpose on each other and can no longer

▶ be properly decoded. The method used therefore ensures that the packets in the next transmission window are sent with a time delay and that each individual tire is clearly detected by the central receiver module.

### Transparent data analysis

Software libraries in the standard programming language C let you change data telegram analysis without any special knowledge. An open source code

allows quick adaptation to customer-specific requirements. Since all these functions interact optimally, test times are extremely short, making for high throughput in the production line.

Each tire pressure sensor transfers a unique ID number together with the pressure, temperature and acceleration data. The central receiver can thus clearly detect the respective tire, even after a tire change (FIG 5). A checksum at the end of the data telegram prevents erroneous analysis of the content.

### Summary

With just 15 height units, the compact R&S®TS7810 can be easily integrated into any production line. As an all-in-one turnkey solution, the system is also ideal for development, quality assurance and incoming goods inspection. If you want to integrate your own system components during a project, you can complement them with individual units and software modules of the R&S®TS7810, for example to retain the software user interface you are familiar with.

Erwin Böhler

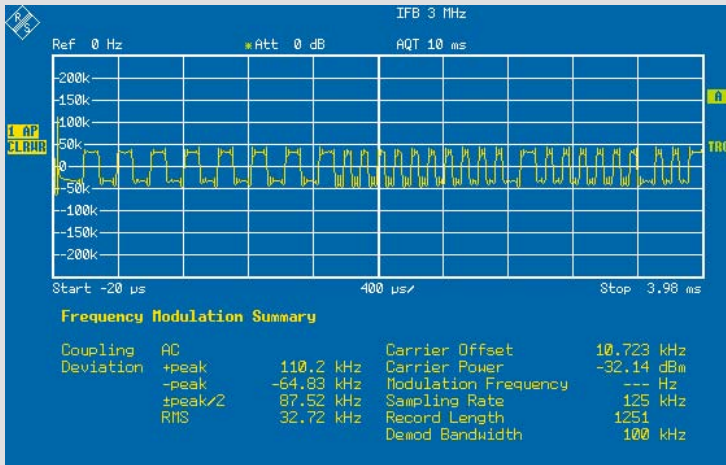

FIG 5 Typical structure of a data telegram (12 bytes).

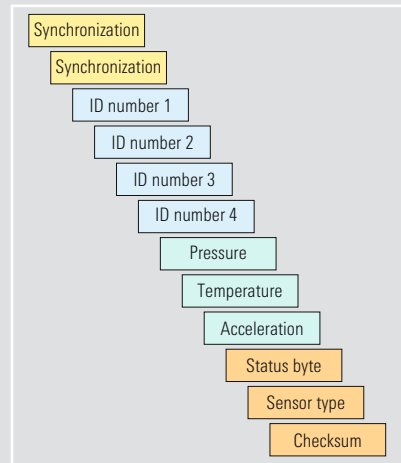

FIG 3 Demodulated data telegram with the FM Measurement Demodulator R&S®FS-K7.

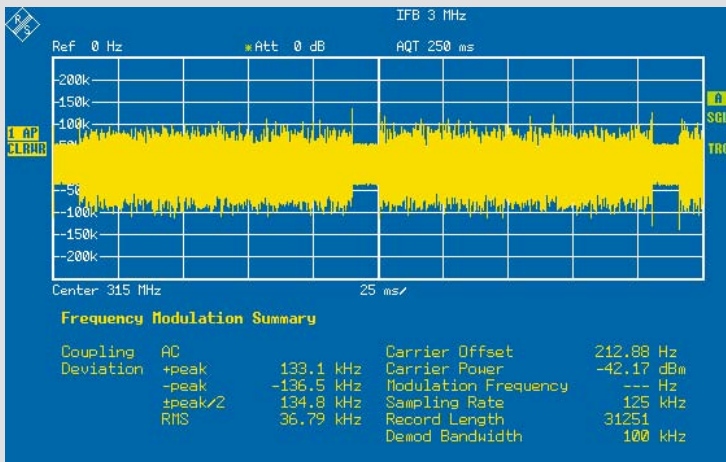

FIG 4 Repetition of three consecutive data telegram with variable pause.

**More information at**  
[www.testsystems.rohde-schwarz.com](http://www.testsystems.rohde-schwarz.com)  
 (production test)

REFERENCES

- [1] Open Test Platform R&S®CompactTSVP: Modular test equipment based on CompactPCI/PXI. News from Rohde & Schwarz (2003) No. 180, pp 14–20
- [2] Versatile Shielded RF Test Fixture R&S®TS 7110: Test fixture for modules and units with radio interface. News from Rohde & Schwarz (2003) No. 179, pp 4–7



**FIG 1** The new Signal Analyzer Module R&S®TS-PAM for multichannel and parallel data acquisition provides floating measurement technology – a feature that is in demand especially in the automotive industry.

## Signal Analyzer Module R&S®TS-PAM for the R&S®CompactTSVP Floating, parallel signal analysis based on CompactPCI/PXI

### The Signal Analyzer Module

R&S®TS-PAM expands the range

of measurement and switching

modules for the Open Test Platform

R&S®CompactTSVP. These modules are

used in function and in-circuit tests

of electronic modules. A distinctive

feature of the new module for multi-

channel and parallel data acquisition

is floating measurement technology –

which is in demand especially in the

automotive industry.

### Continuously improving

The CompactPCI/PXI-based Open Test Platform R&S®CompactTSVP from Rohde & Schwarz [\*] provides a fundamental range of T&M functionalities and communication interfaces for hardware and software. Since application scenarios for a such an industrial test platform are permanently changing, the platform needs to be improved continuously and without delay.

The new Signal Analyzer Module R&S®TS-PAM (FIG 1) is the answer to the constant demand for floating measurement with integrated signal conditioning and switching. Its measurement card permits multichannel recording of analog and digital data, in a similar way as a mixed-signal oscilloscope. A free, hardware-independent analysis library simplifies the evaluation of recorded sig-

nals with regard to their waveform and time characteristic.

### Flexibility ensures success

The R&S®TS-PAM includes two independently operating measurement units. Their recording method and sampling frequencies are user-configurable (FIGs 2 and 3). Each unit has four input channels that are sampled by an A/D converter with a quick 4:1 multiplexer, either statically or quasi-simultaneously by means of a special scan method. The measured signals are routed to the measurement unit either directly via the front connector of the module or from the switching modules via the analog measurement bus of the Open Test Platform R&S®CompactTSVP. The separately programmable input sensitivities of the eight channels allow you ▶



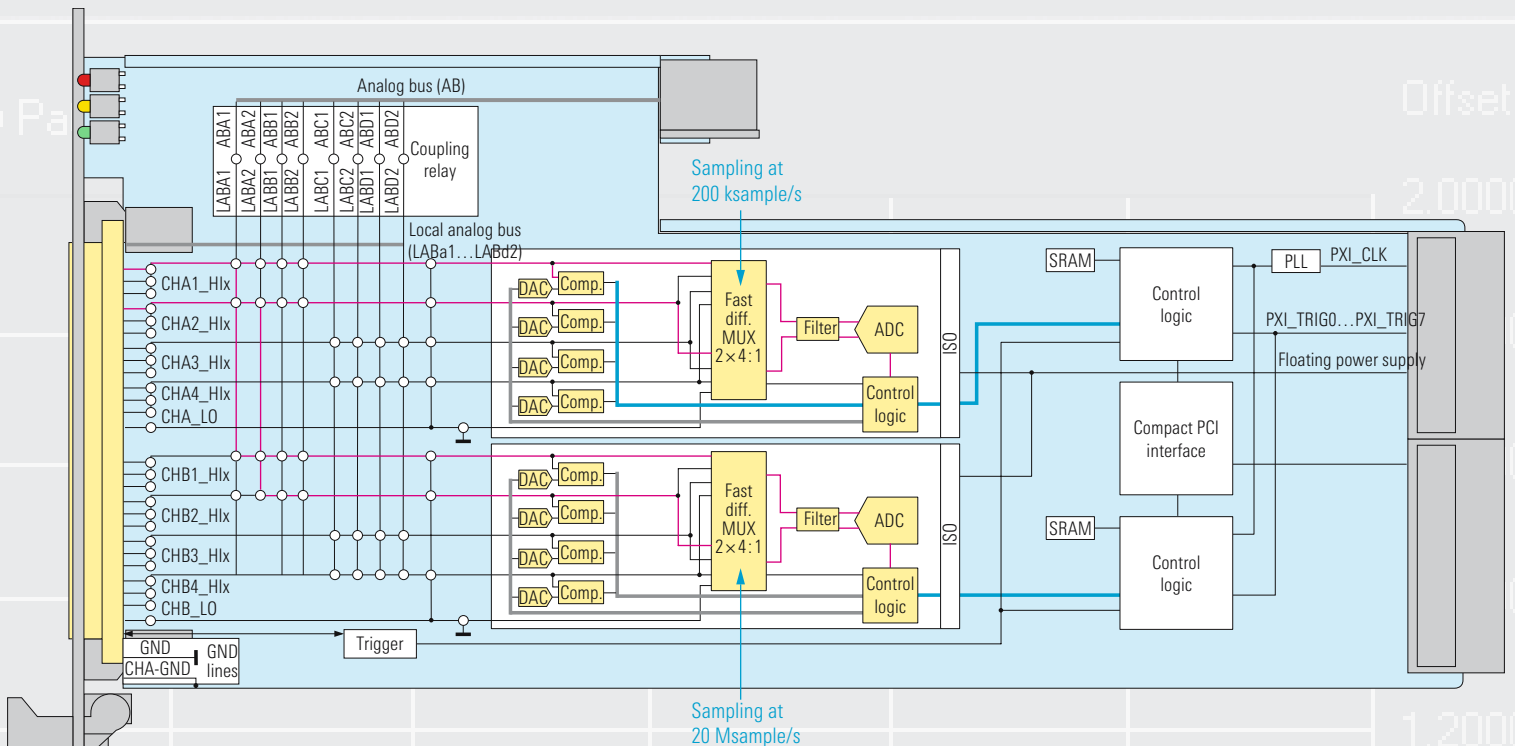

**FIG 2** Block diagram of the Signal Analyzer Module R&S®TS-PAM showing the path of the signals to be analyzed (red) and the trigger signals (blue).

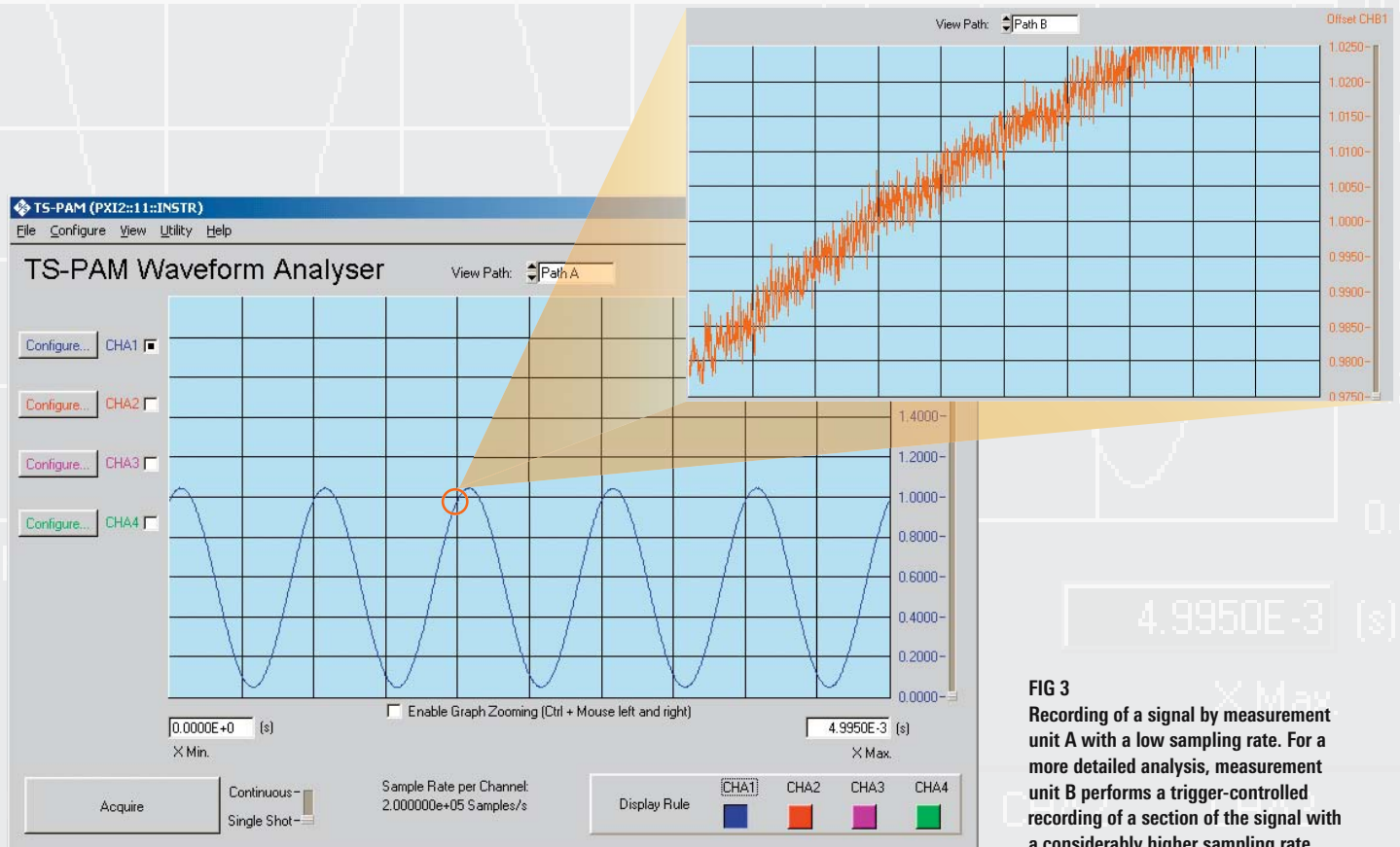

**FIG 3** Recording of a signal by measurement unit A with a low sampling rate. For a more detailed analysis, measurement unit B performs a trigger-controlled recording of a section of the signal with a considerably higher sampling rate.

- ▶ to simultaneously record signals in the millivolt range as well as up to 100 V.

In single-channel mode, the maximum clock rate is 20 Msample/s per measurement unit. With simultaneous recording, you can achieve a sampling rate of 5 Msample/s for each channel. In both operating modes, the analog data is continuously stored on the module together with the status of the digital trigger inputs. In conjunction with pre- and post-triggering, you can perform an analysis of the measurement data with regard to time by using digital reference signals. Each input channel is able to trigger its own measurement unit as well as further measurement and stimuli cards via a PXI trigger bus.

### All-inclusive features for keeping up with the times

The Signal Analyzer Module R&S®TS-PAM provides a functional software interface that permits interactive operation. This interface makes it easier for you to configure the switching paths and the measurement units, and thus to interactively perform measurement tasks during system integration.

For convenient test program development, the powerful and hardware-independent R&S®GTSL software packet is available. Like all cards of the R&S®CompactTSVP product line, the R&S®TS-PAM module also offers self-test capabilities allowing functionality diagnosis as part of a system selftest. This reduces costs caused by production losses as a result of long downtimes.

### Summary

With its R&S®TS-PAM, Rohde & Schwarz is the first company to offer a signal analyzer module with floating and parallel data acquisition measurement technology. This is an important basic functionality of a state-of-the-art test platform, especially in the automotive field. Flexible configuration possibilities of the measurement units in conjunction with extensive software support make it possible to solve even complex measurement tasks using only one module.

Owing to the extensive portfolio of measurement and stimuli cards and the unique system concept of the R&S®CompactTSVP, Rohde & Schwarz is able to offer its customers innovative solutions for the production of electronic components.

Christian Hof; Michael Grandauer

Type	Description	Data sheet
R&S®TS-PCA3	Test and Measurement Platform	PD 0758.0597.32
R&S®TS-PWA3	Switching Application Platform	PD 0758.0622.32
R&S®TS-PSAM	Analog Source and Measurement Module	PD 0758.0580.32
R&S®TS-PICT	In-Circuit Test (ICT) Extension Module	PD 0758.1964.32
R&S®TS-PDFT	Digital Functional Test Module	PD 0758.0645.32
R&S®TS-PFG	Arbitrary Waveform and Function Generator Module	PD 0758.0639.32
R&S®TS-PAM	Analyzer and Data Acquisition Module	PD 0758.0668.32
R&S®TS-PMB	Switching Matrix Module	PD 0758.0600.32
R&S®TS-PSM1	Power Switching Module	PD 0758.0616.32

Further data sheets for the R&S®TSVP product line.

### Abbreviations and instrument designations

CompactPCI	Standardized PCI-based bus system for industrial use.
PXI	PCI-eXtension for Instrumentation – extension of CompactPCI to synchronize T&M modules via reference clock and trigger lines.
R&S®CompactTSVP	Test system versatile platform – platform concept for PC-based T&M equipment with CompactPCI/PXI from Rohde & Schwarz.
R&S®GTSL	Generic test software library – comprehensive library of software from Rohde & Schwarz.

More information and data sheets at [www.rohde-schwarz.com](http://www.rohde-schwarz.com)



R&S®CompactTSVP



R&S®TS-PAM

For more information and data on the Signal Analyzer Module R&S®TS-PAM, refer to the data sheet.

The Open Test Platform R&S®CompactTSVP brochure provides an overview of the R&S®CompactTSVP modules with specifications and application notes. Visit the Internet pages of Rohde & Schwarz to download the data sheets of the individual measurement and stimuli cards (table left).

REFERENCES

[\*] Modular test equipment based on CompactPCI/PXI. News from Rohde & Schwarz (2003) No. 180, pp 14–20

## Spectrum Analyzer R&amp;S®FSL

# A multipurpose instrument you won't want to miss

## The new Spectrum Analyzer R&S®FSL

(FIG 1) is ideal for many applications: It is versatile for laboratory use, its lightweight and portable design makes it suitable for mobile use and it is fast in production. And all this is offered at a very favorable price. Once you have started to work with it, you won't want to part with it anymore ...

## Unique in its price range

A spectrum analyzer is required for many applications, e. g. to measure the level and frequency of a signal or determine unwanted signals or interference. In many cases, however, the important thing is not the dynamic range or phase noise but a solution that is as cost-efficient as possible. And this is definitely offered by the Spectrum Analyzer R&S®FSL.

Its light weight, compact size and optional battery operation make it ideal for mobile use. Due to its extensive functionality, it is nevertheless a full-featured

analyzer for general use in the laboratory, development or service. Production specialists will appreciate its high measurement speed and its high level accuracy – excellent features combined with a favorable price.

The R&S®FSL is available in four different versions as a 3 GHz and 6 GHz model (FIG 2). The instrument has a number of excellent features that are unique in its price range, e. g.:

- ◆ The large I/Q demodulation bandwidth of 20 MHz and the wide bandwidth from 1 Hz to 10 MHz.



**FIG 1**  
The R&S®FSL has a lightweight and extremely compact design. Yet it is a full-featured spectrum analyzer offering extensive functionality and the best RF characteristics of its class.



- ◆ The high 3rd order intercept point of typ. 15 dBm yielding excellent large-signal immunity.
- ◆ Its easy and customized configuration: all options can be installed or added without having to open the analyzer.

## Excellent performance

Featuring a phase noise of  $-103$  dBc (1 Hz) at 10 kHz from the carrier, a 3rd order intercept point of typ.  $+15$  dBm, a bandwidth of 10 Hz to 10 MHz (with FFT filters even from 1 Hz) and a displayed average noise level of  $-152$  dBm (1 Hz) with preamplifier, the R&S®FSL ranks among higher-class analyzers. This makes it the ideal tool not only in production but also in service, for field applications and in the laboratory. An electronic RF attenuator settable in 5 dB steps and an optional preamplifier optimize the usable dynamic range.

For most spectrum analyzers, the frequency range of internal tracking generators is limited to approx. 3 GHz. The tracking generator of the R&S®FSL6, which operates up to 6 GHz, is therefore of special importance. For this reason, you can use the tracking generator in the full frequency range of the R&S®FSL6 to determine, for example, the frequency response of cables in the test setup or matching (with the SWR bridge).

## Options for the R&S®FSL

- ◆ OCXO, aging  $1 \times 10^{-7}$ /year
- ◆ Additional interfaces: video out, IF out, noise source control, AUX port, R&S®NRP power sensor
- ◆ Resolution bandwidths 10 Hz to 100 Hz (1 Hz FFT)
- ◆ Gated sweep
- ◆ IEC/IEEE bus interface
- ◆ DC power supply 12 V to 28 V
- ◆ RF preamplifier
- ◆ NiMH battery pack
- ◆ Power measurement with power sensors of the Power Meter R&S®NRP

## Operation similar to high-grade laboratory equipment

Handling and operation are more or less identical with that of the analyzers of the R&S®FSP and R&S®FSU families. Powerful marker functions are standard as well as the display of up to four traces and many complex measurement functions (see also FIGs 3 to 6). These functions range from preconfigured and user-configurable channel and adjacent-channel power measurements to measurement functions for burst power, user-definable limit lines and C/N to TOI

measurements and phase noise markers. The instrument comes with a full selection of detectors including RMS and quasi-peak detectors as well as a large number of settable points per trace (125 up to max. 32000).

Measurement results can be documented via a printer connected to a USB bus or can be stored as a graphics file on a USB memory stick.

This scope of functions and the excellent RF data together with an excellent price/performance ratio make the R&S®FSL an indispensable tool for any RF task like a multimeter or an oscilloscope.

## Fully digital signal processing

All R&S®FSL models operate as triple converting receivers with high first IF. Frequency tuning is fully synchronous. The frequency accuracy therefore only depends on the TCXO reference and the pixel resolution of the screen.

An A/D converter directly digitizes the signal of the last IF. Signal processing from the last IF on, which means IF filtering, detection and logarithmic conversion, video filtering and signal detection, is purely digital. These functions are thus reproducible and very stable. Level errors caused by bandwidth or detector switching are negligible. The display linearity depends exclusively on the linearity of the A/D converter, whose linearity error is also negligible in practice. The level measurement uncertainty is determined mainly by the frequency response of the input device including the RF attenuator. The frequency response is (as is the case with all other analyzers from Rohde & Schwarz) stored in the device. The displayed level is corrected for any frequency and attenuator setting. This ensures a level measurement uncertainty of only 0.5 dB up to 3 GHz and 0.8 dB to 6 GHz.

FIG 2 Overview of available models.

Model	Frequency range	Tracking generator
R&S®FSL 3, model 03	9 kHz to 3 GHz	no
R&S®FSL 3, model 13	9 kHz to 3 GHz	1 MHz to 3 GHz
R&S®FSL 6, model 06	9 kHz to 6 GHz	no
R&S®FSL 6, model 16	9 kHz to 6 GHz	1 MHz to 6 GHz

▶ With the R&S®FSL-K9 option, the R&S®FSL attains an even better measurement uncertainty like that offered by high-accuracy power sensors. This option supports the direct connection of all the power sensors of the Power Meter R&S®NRP. The R&S®FSL therefore replaces a power meter – which is especially interesting for mobile use.

Due to the digital implementation, the analyzer offers resolution filters of different characteristics, for instance RRC filter, channel filter or filters for EMI precompliance measurements. Digital implementation ensures not only a negligible level error when you want to switch over between different bandwidths but also a high accuracy of the set bandwidth itself. This is of vital importance for a low measurement uncertainty in the case of channel or adjacent-channel measurements (ACP).

The large bandwidth of the last IF and the high sampling rate of the A/D converter form the basis for the large bandwidth offered by the R&S®FSL.

### Fast and versatile in production

The R&S®FSL is ideal for fast and easy measurement tasks in production, since often the only important thing is to measure level and frequency as quickly as possible. With its high measurement speed of >80 sweeps/s in the zero span and output of data or trace data in the remote-control mode, the R&S®FSL ensures a high throughput.

Moreover, the analyzer saves time in production, since it offers a variety of special measurement functions:

- ◆ The R&S®FSL simplifies and accelerates level calibration, which is often necessary for transmit modules, by

means of integrated complex measurement functions such as the special multisummary marker. This marker measures different levels in the time domain in a single run, eliminating return times and remote-control bus overhead.

- ◆ The R&S®FSL measures the power of modulated signals using the fast ACP function offered by channel filters. This is done for the most important mobile radio standards in the time domain at a very good repeatability and short measurement times.
- ◆ Owing to its fast frequency counter, the R&S®FSL determines the transmit frequency with a resolution of 1 Hz in less than 50 ms.
- ◆ In the list mode, the R&S®FSL operates like a selective power meter and handles up to 300 different settings with only a single remote-control command. The R&S®FSL offers a special trigger interface to enable

**FIG 3 Phase noise measurement with phase noise marker**  
You use the phase noise marker to quickly estimate the phase noise at a certain carrier offset. For the result in dBc (1 Hz), the phase noise marker considers all necessary corrections relating to the noise bandwidth of the filters, the detectors used and averaging. The phase noise of the R&S®FSL of typ. -103 dBc (1 Hz) at 10 kHz from the carrier is sufficient for many measurement tasks on oscillators.

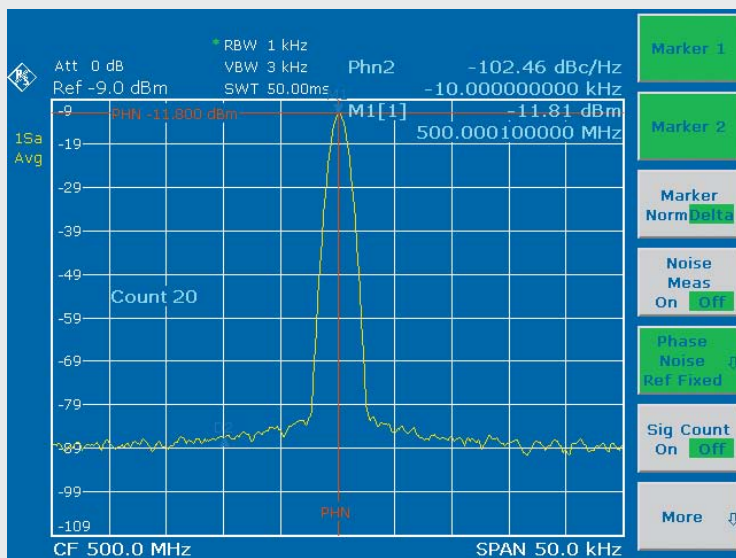

**FIG 4 Gated sweep**  
The R&S®FSL uses the gated sweep function for measurements on burst signals and can thus display the spectrum of WLAN packets, for example, and exactly measure their power. The traces indicate the comparison between a measurement with (yellow) and without (blue) the gate function. The IF power trigger supports the measurement in cases where no external trigger signal is available.

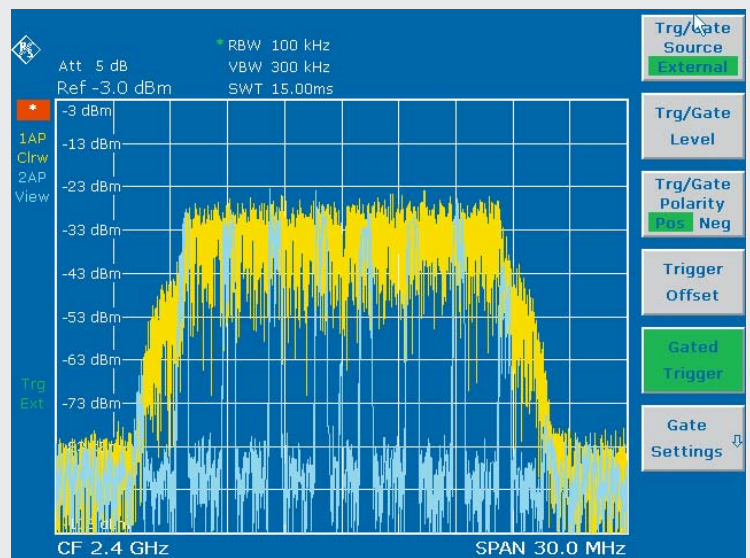

fast synchronization or triggering in this mode. This interface is offered by the optional Additional Interfaces R&S®FSL-B5.

The standard remote-control interface is 10/100BaseT, which is much faster than the IEC/IEEE bus in transmitting large volumes of data. An IEC/IEEE bus interface can be installed as an option.

The standard electronic RF attenuator setting ensures utmost reliability. Problems occurring with mechanically switched attenuators during high switching cycles are unknown to the R&S®FSL.

### Easy extendibility

The R&S®FSL has a unique concept for retrofitting options using plug & play: All options can be retrofitted without

having to open the unit. This concept offers a variety of advantages:

- ◆ No additional adjustment after installation
- ◆ No recalibration
- ◆ No need to send the instrument in and thus no downtimes
- ◆ No installation costs
- ◆ Easy extendability for additional tasks

Herbert Schmitt

More information and data sheet at [www.rohde-schwarz.com](http://www.rohde-schwarz.com) (search term: FSL)

### Condensed data of the R&S®FSL

Frequency range	depending on model: 9 kHz to 3 GHz or 6 GHz 1 kHz at 1 GHz, optional 100 Hz at 1 GHz
Frequency uncertainty	
Resolution bandwidth	
Standard	300 Hz to 3 MHz in 1/3 sequence
With option R&S®FSL-B7	10 Hz to 10 MHz in 1/3 sequence, add. 1 Hz (FFT filter)
Video bandwidths	1 Hz to 10 MHz
I/Q demodulation bandwidth	20 MHz
Phase noise	typ. -103 dBc (1 Hz), at 10 kHz from carrier, 1 GHz
Displayed average noise floor	
At 1 kHz RBW, 50 MHz < f < 3 GHz	-110 dBm
At 10 Hz RBW and with preamplifier (options R&S®FSL-B7/22), 50 MHz < f < 3 GHz	-142 dBm
TOI	10 dBm, typ. 15 dBm
Detectors	Pos/Neg Peak / Auto Peak, RMS, QuasiPeak, Average, Sample
Level measurement uncertainty	<0.5 dB for f < 3 GHz, 0.8 dB for 3 GHz < f < 6 GHz

FIG 5 Scalar network analyzer

The R&S®FSL uses the tracking generator of models 13 and 16 to quickly and easily perform frequency response, filter and attenuator measurements. The n-dB down marker determines, for example the 3 dB bandwidth of a bandpass filter at a keystroke. The analyzer uses an external measurement bridge to measure the analyzer return loss or matching. Through, Short and Open calibration increases the accuracy.

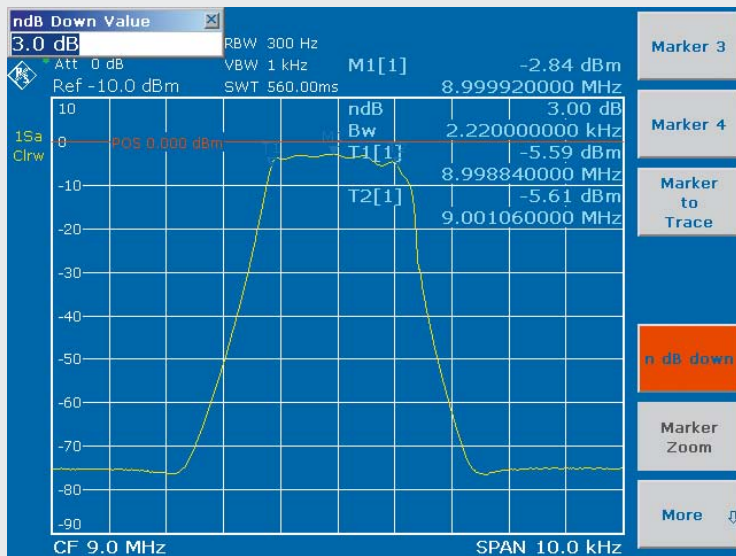
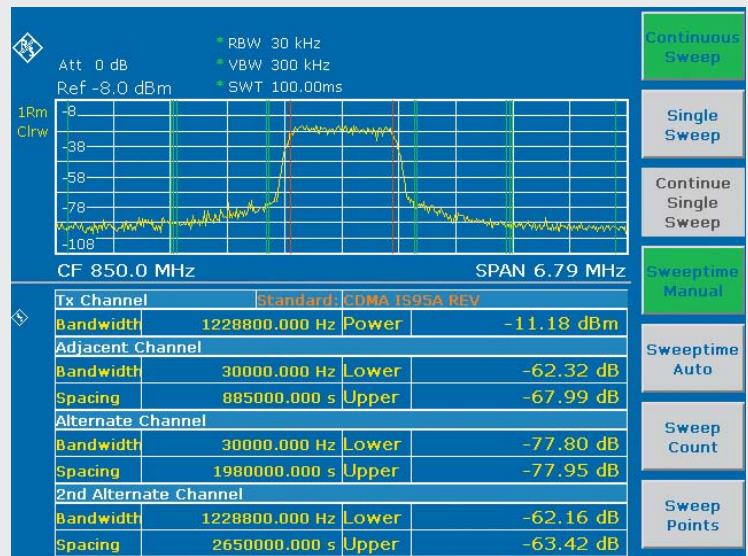
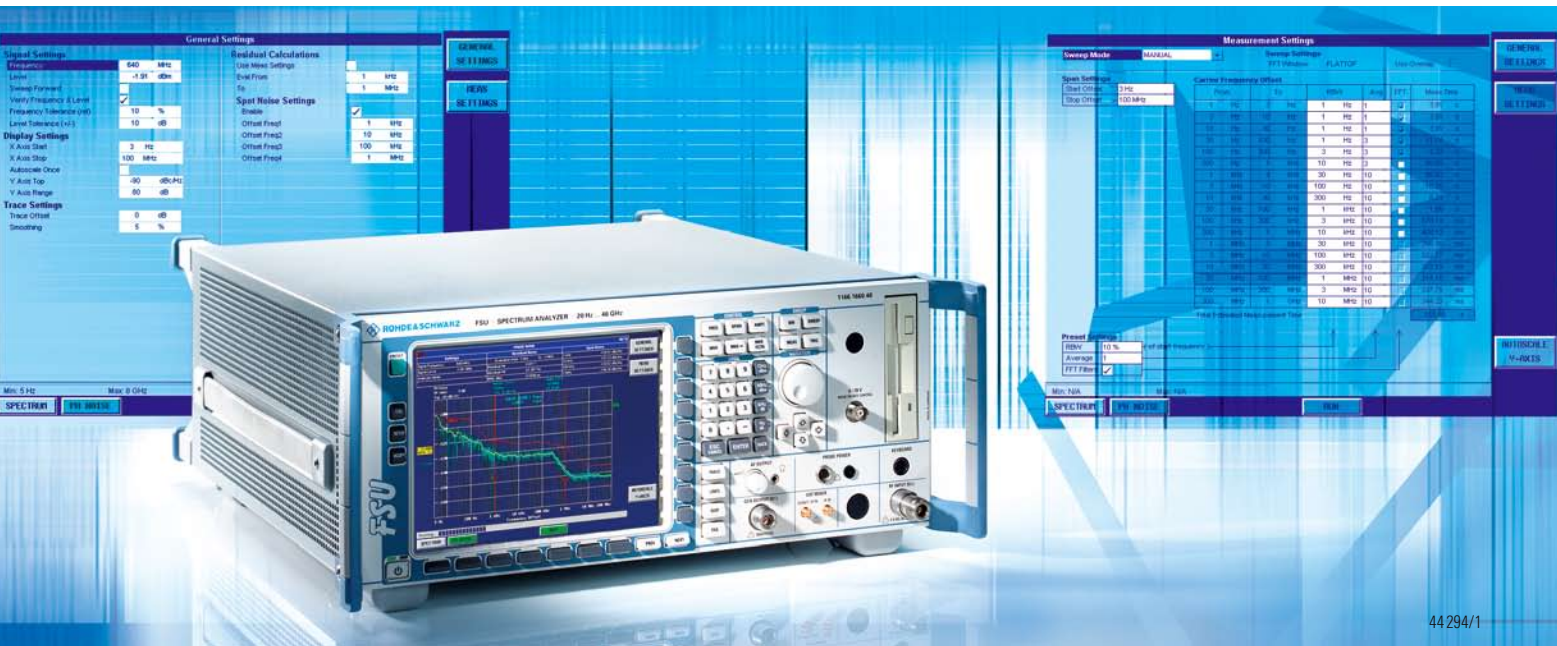

FIG 6 Adjacent-channel measurement

The ACP measurement function determines the adjacent-channel power in absolute values or with reference to the useful carrier. In addition to many predefined settings offered by the R&S®FSL for many transmission standards, this measurement is largely user-definable: you can enter different channel widths and channel spacings for up to 12 useful and three adjacent channels.







44294/1

**The new Application Firmware R&S®FS-K40 for the Analyzers R&S®FSP/FSU/FSQ measures the phase noise of signal sources. Being an integral part of the instrument software, it can make full use of the dynamic range, speed and remote control capabilities of the measuring instrument. In conjunction with the low phase noise of the high-end Analyzers R&S®FSU and R&S®FSQ, which has now been even further reduced, the R&S®FS-K40 yields testers of uniquely low phase noise.**

**Spectrum Analyzers R&S®FSP/FSU/FSQ**

**Phase noise testers of unparalleled quality**

**R&S®FS-K40 – integral part of instrument software**

Low phase noise of transmitter and receiver oscillators is crucial for the quality of transmit signals and therefore a key parameter in designing radiocommunications applications. High phase noise not only impairs modulation quality but also increases the power level in the neighboring channels, thus reducing transmission quality for other subscribers.

R&S®FS-K40 is the follow-up to the Phase Noise Measurement Software R&S®FS-K4 from Rohde & Schwarz. In contrast to R&S®FS-K4, which is installed on an external PC, the new firmware is integrated in the analyzer software. It can thus be started directly

from the analyzer's user interface and is completely remote-controllable via the IEC/IEEE bus or a LAN.

**Settings and results with the accustomed high convenience**

The basic parameters for phase noise measurements, e.g. carrier frequency and level, are entered in the GENERAL SETTINGS menu (FIG 1). The firmware automatically checks whether the amplitude and frequency of the incoming carrier are within predefined tolerances, and interrupts the measurement in the event of large deviations from set values. You can set the x- and y-axis display ranges, the residual FM and  $\phi$ M measurement ranges and – as a special feature – the direction of measurement.

This means that measurements can also be started at maximum carrier offset – at large resolution bandwidths and thus short sweep times. This produces results quickly, and you can immediately change instrument settings if required.

When you press the MEAS SETTINGS softkey, R&S®FS-K40 displays a list of all sweep parameters relevant to the measurement (FIG 2). You can choose the sweep modes listed below for the selected measurement range (shown with a green background in FIG 2), depending on whether your application calls for short measurement time or high reproducibility:

- ◆ FAST (time-optimized measurement)
- ◆ NORMAL
- ◆ AVERAGED (over a high number of sweeps)
- ◆ MANUAL

You can also manually select all parameters such as the filter type, filter bandwidth and number of averaged sweeps for each carrier offset subrange or preset these parameters for the full measurement range.

In addition to the menus specifically for phase noise measurement, the firmware also provides further functions known from other spectrum analyzer applications. For example, you can perform pass / fail tests with the aid of user-definable limit lines. You can export data in ASCII format, store all parameter settings and display several traces simultaneously. Apart from the common trace functions such as averaging over several sweeps, trace smoothing is also performed.

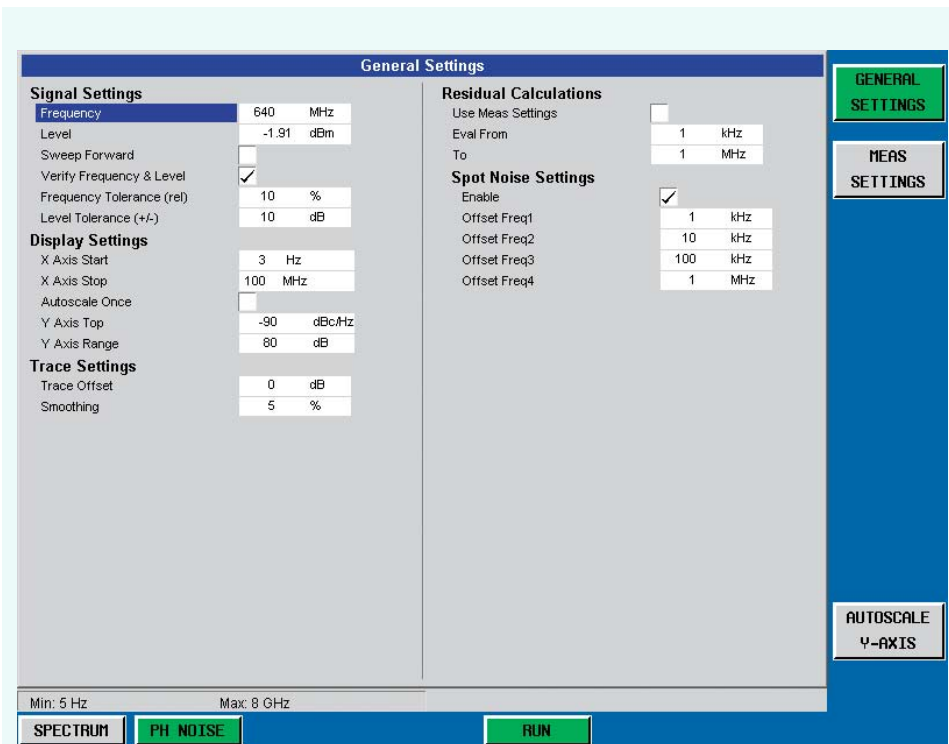

**FIG 1** GENERAL SETTINGS menu for setting the global phase noise measurement parameters. The basic measurement parameters (carrier level and frequency, display ranges, etc), the residual FM and  $\phi$ M measurement ranges as well as discrete offset frequencies are entered here.

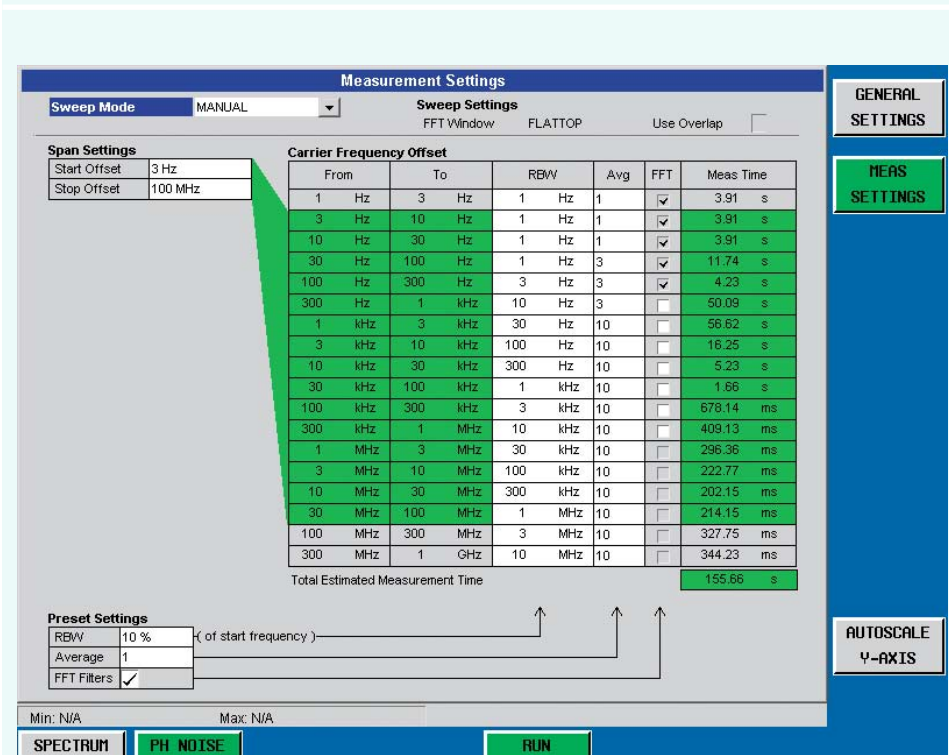

**FIG 2** Overview and menu for setting the measurement range, filters and number of sweeps to be averaged. Setting of sweep parameters: The area on the left with a green background indicates the currently selected offset frequency measurement range. The fields with a white background can be edited.

► **R&S®FSU and R&S®FSQ phase noise now even lower**

The Spectrum Analyzers R&S®FSU and the Signal Analyzers R&S®FSQ of the newest generation (from serial No. 2xxxxx) feature significantly better

phase noise than their predecessors (FIG 3). The spectrum analyzer's inherent phase noise is the minimum limit of sensitivity in direct measurements of signal sources. To attain a measurement uncertainty below 1 dB, for example, the inherent phase noise of the instru-

ment must be at least 6 dB lower than the phase noise of the signal under test. In its Analyzers R&S®FSU and R&S®FSQ, Rohde & Schwarz now offers instruments of uniquely low phase noise. In conjunction with the R&S®FS-K40 firmware, this yields high-grade phase noise testers.

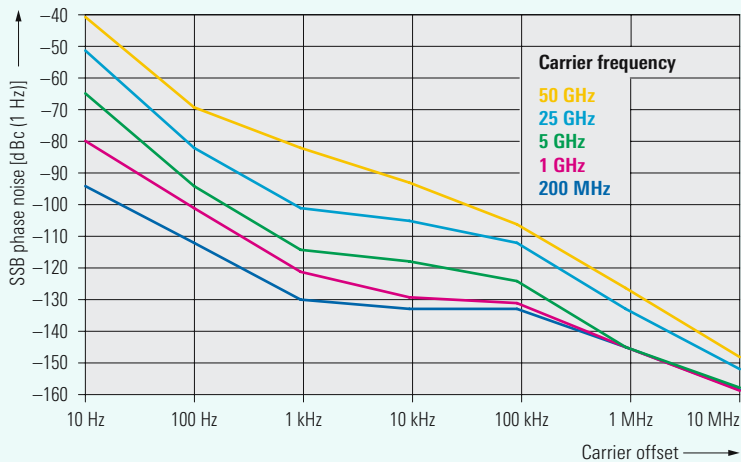

**FIG 3** Typical phase noise values of the Spectrum Analyzers R&S®FSU and the Signal Analyzers R&S®FSQ at various input frequencies versus the carrier offset frequency.

**Results at a glance**

The R&S®FS-K40 firmware presents key results at a glance in a straightforward manner (FIG 4). In the default mode, the original trace and the smoothed trace are displayed together. A status bar at the lower edge of the screen indicates measurement progress and helps you to assess the remaining measurement time. If you start phase noise measurements at offset frequencies far from the carrier, results for the subranges of interest will be available very quickly due to the increased measurement speed at large bandwidths.



**FIG 4** Typical result of a phase noise measurement at 10 Hz to 100 MHz offset from the carrier. The vertical red lines EL1 and EL2 mark the range limits for residual FM and  $\phi$ M measurements. The red curve is the user-defined LIMIT. The measurement result (Pass in this example) is displayed at the top center of the diagram. A smoothed trace (yellow) is superimposed on the original trace (green). The blue bar (Running) at the lower edge of the screen indicates measurement progress and helps you to assess the remaining measurement time.

A comparison of results against limit lines also takes place after each subrange measurement. Traces are automatically scaled in the default mode. The main measurement parameters such as the signal frequency and amplitude are displayed in a table at the top of the screen. This table also shows the measured residual FM and  $\phi$ M, RMS jitter and the phase noise values at specific offset frequencies.

Dr Wolfgang Wendler

More information, data sheet and manual at [www.rohde-schwarz.com](http://www.rohde-schwarz.com) (search term: FS-K40)



Conditions in production place heavy demands on a signal source. High setting speeds ensuring maximum throughput without any detrimental effect on signal quality have top priority. The R&S®SMATE200A meets these requirements. It offers special additional details that make it particularly attractive.

## Vector Signal Generator R&S®SMATE200A

# The rugged specialist for everyday use in production

### Sturdy and fast

The new Vector Signal Generator R&S®SMATE200A (FIG 1) is ideally suited to meet production requirements. The R&S®SMATE200A differs distinctly from the high-end Vector Signal Generator R&S®SMU200A but is based on its hardware. The most obvious difference is the modified housing: The R&S®SMATE200A has no display or control keys. All connectors are at the rear.

But there are also special features inside: the R&S®SMATE200A offers an extremely short setting time of <2 ms for frequency and level changes (FIG 2). This increases the throughput in production and thus saves production costs by reducing test times. If even shorter setting times are required, it is advisable to use the List mode, since frequency and level values can be stored beforehand. The R&S®SMATE200A then attains setting times of <400  $\mu$ s for frequency

In addition to the R&S®SMATE200A, Rohde & Schwarz has launched another innovative generator: the R&S®SMJ100A, which is described on page 30. An overview of all members of the generator family is provided on page 33.

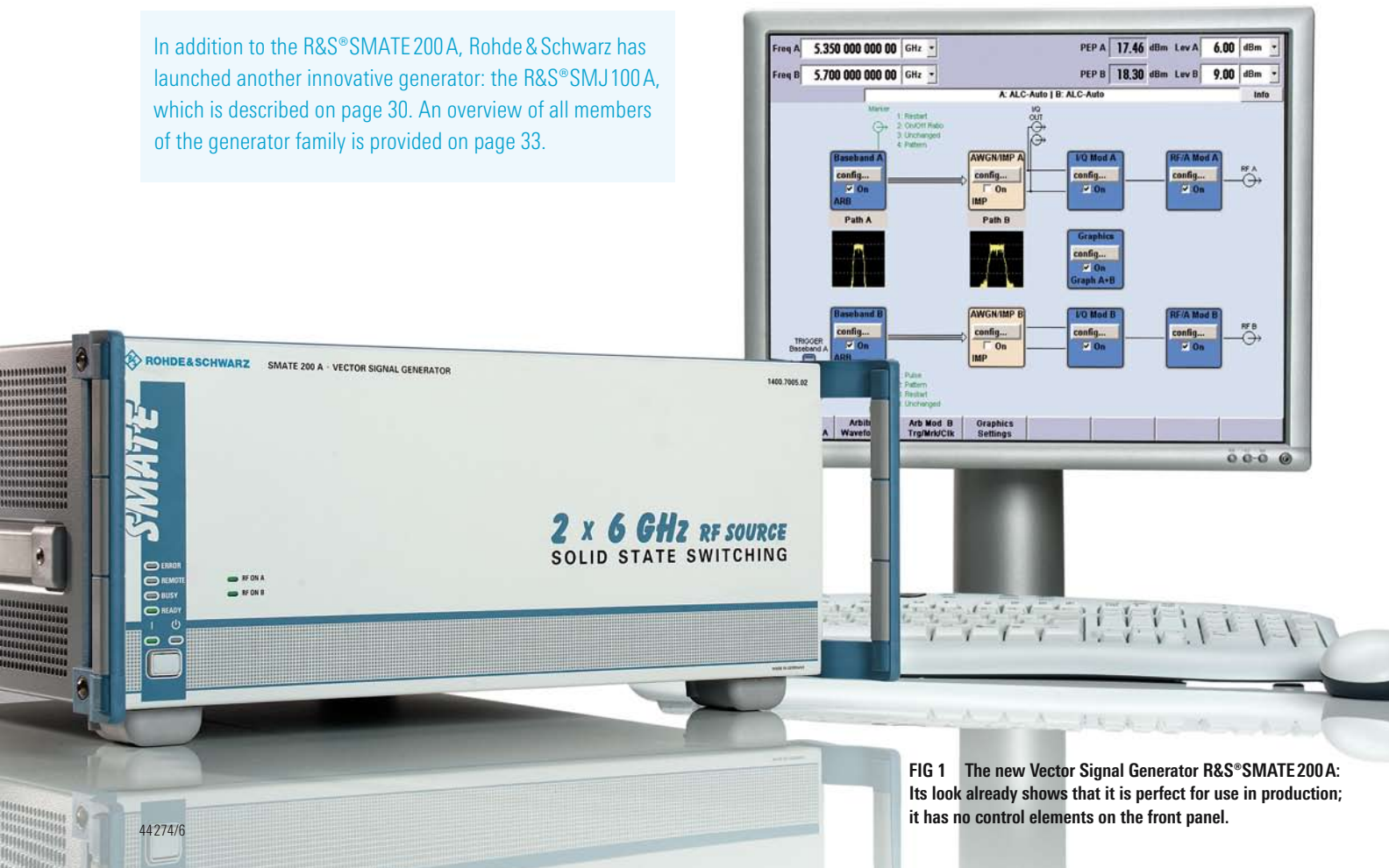

FIG 1 The new Vector Signal Generator R&S®SMATE200A: Its look already shows that it is perfect for use in production; it has no control elements on the front panel.

► changes. The List mode becomes flexible owing to the Fast Hop mode: Up to 10000 entries can arbitrarily be addressed via a serial bus.

### Tailored to meet production requirements

In addition to short setting times, the new generator also offers a variety of other advantages that make it ideal for use in production. Space requirement is often a decisive factor. The R&S®SMATE200A has a two-path concept that allows up to two independent signal sources in a cabinet of only four height units. Options for extending the frequency range up to 3 GHz or 6 GHz can be used as required. The

R&S®SMATE200A offers up to two RF sources, and up to two baseband generators can be added. External baseband sources are thus obsolete owing to the flexibility of the baseband generators and the large memory depth of the internal arbitrary waveform generator – yet another advantage to save space and thus costs.

But the baseband generator has even further potential: setting times can occur not only in the RF section but also when you switch over between digital signals. Production often calls for precalculated waveforms that must be switched over quite quickly. The R&S®SMATE200A can store a variety of different signals and switch over between them within only typ. 5 µs.

### Fit for tough production requirements

Instruments in continuous use in production have to meet the most stringent requirements. The new generator together with its electronic attenuator meets these requirements: It is wear-free and does not require any special maintenance.

Moreover, the R&S®SMATE200A offers an optimized cooling concept: This is of vital importance in racks, since the ambient temperature is often higher than in labs. Low temperature in the instrument means less stress on the components and thus a longer life and, last but not least, very short downtimes for the test system.

### Signal quality without concessions

Despite all these special characteristics, the R&S®SMATE200A makes no concessions with regard to signal quality. Signal quality is identical to that of the R&S®SMU200A high-end generator. As far as the SSB phase noise is concerned, the new generator offers typ. –135 dBc (1 Hz measurement bandwidth, carrier frequency 1 GHz, 20 kHz offset) even in the standard version. With the Low Phase Noise option, this value can be improved by yet another 5 dB to typ. –140 dBc (FIG 3). Such excellent data is required for testing chips, for example.

Another important factor for use in production is the available level, in order to compensate for losses occurring in the test setup. Even in its basic version, the R&S®SMATE200A offers output levels of +13 dBm (FIG 4). The generator has a High-Power Output option to compensate for higher losses or to provide modules with higher levels. This option increases the output level by 6 dB to obtain +19 dBm. However, not only is

#### Condensed data of the R&S®SMATE200A

<b>Frequency</b>		
Frequency range		100 kHz to 3 GHz / 6 GHz
Setting time		<2 ms
Setting time in List mode		<400 µs
<b>Level</b>		
Range		–144 dBm to +13 dBm (PEP) [+16 dBm in overrange]
Range with High-Power Output option		–144 dBm to +19 dBm (PEP) [+26 dBm in overrange]
Setting time		<2 ms for $f \leq 3$ GHz <4 ms for $f \geq 3$ GHz
<b>Spectral purity</b> (at $f = 1$ GHz)		
Nonharmonics	carrier offset >10 kHz	<–80 dBc
	carrier offset >850kHz	<–86 dBc
SSB phase noise	(carrier offset 20 kHz, 1 Hz measurement bandwidth)	typ. –135 dBc, typ. –140 dBc (with Low Phase Noise option)
Broadband noise	(carrier offset >5 MHz, 1 Hz measurement bandwidth)	typ. –153 dBc (CW) typ. –149 dBc (I/Q modulation)
<b>ACLR performance</b>		
3GPP FDD test model 1, 64 DPCH		typ. 70 dB
<b>I/Q bandwidth</b> (RF)		
Internal		80 MHz
External		200 MHz
<b>Arbitrary waveform generator</b>		
Memory depth		16 Msamples / 64 Msamples
<b>Interfaces</b>		
		IEEE 488.2, LAN (Gigabit Ethernet), 2 × USB, 1 × USB slave, VGA

the level's maximum value important in production, but also its repeatability, i.e. the aim is to ensure the same conditions versus time. The high level repeatability of the R&S®SMATE200A allows lower tolerances during the tests and thus increases the production yield.

## Summary

The family concept of the generators offered by Rohde & Schwarz is paying off: In addition to the R&S®SMU 200A high-end generator for laboratory use, the R&S®SMATE200A is now offered for use in production. This is a decisive factor for the user, since the same performance in development and production is ensured.

The new Vector Signal Generator R&S®SMATE200A combines the advantages of the R&S®SMU 200A regarding signal quality and two-path concept with special functions like Fast Hop bus and very low setting time. Its hardware design underlines that it is ideal for production applications.

But that's not all: Another member of the family is introduced on the next page – the R&S®SMJ100A. This generator has a strictly single-path concept and is interesting mainly for users looking for an excellent vector signal generator without special features such as a two-path concept or fading.

Markus Lörner

**FIG 2** The frequency setting time of the R&S®SMATE200A is typ. 1.2 ms.

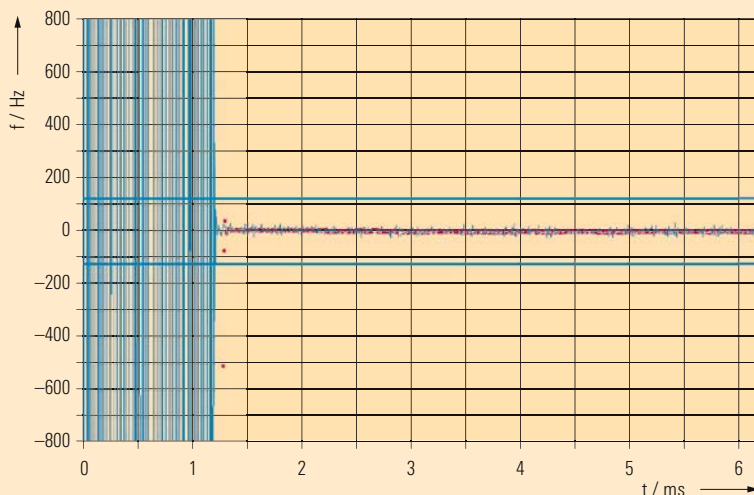

**FIG 3** Excellent SSB phase noise with Low Phase Noise option: typical traces for different frequency bands.

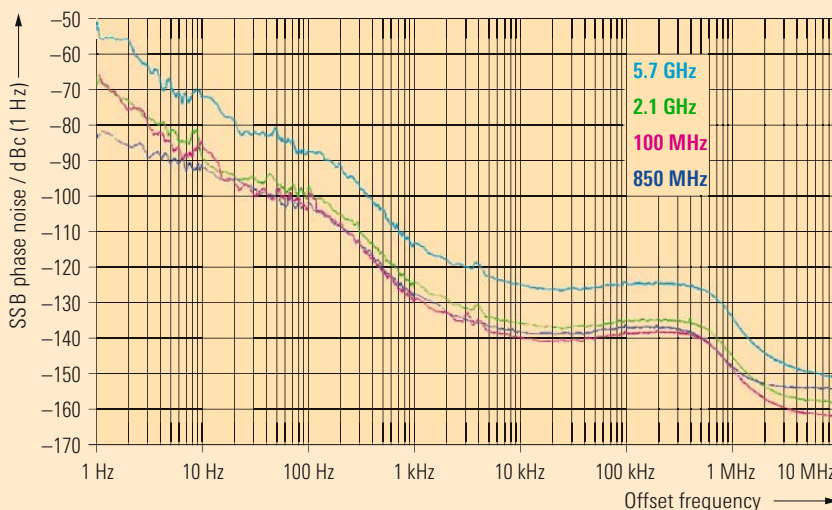

**FIG 4** High output levels over the complete frequency range.

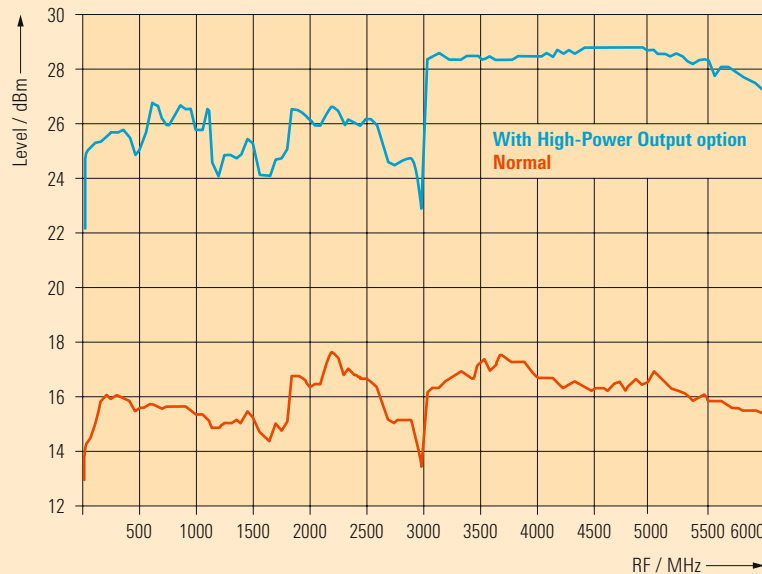



## Vector Signal Generator R&amp;S®SMJ 100A

# The all-purpose generator that redefines the medium segment

First the R&S®SMU200A vector signal generator, followed by the R&S®SMATE200A production specialist (page 27) – and now Rohde & Schwarz is launching the third member of this family: the R&S®SMJ 100A, which is definitely an all-purpose generator.

## High-end signal quality in the upper medium segment

In a way, the R&S®SMJ 100A (FIG 1) might be considered the R&S®SMU200A's "little brother", since it is essentially based on the concept of the R&S®SMU200A. The R&S®SMJ 100A has adopted the R&S®SMU200A's platform plus its successful operating concept (FIG 2).

With its strictly single-path design, the R&S®SMJ 100A primarily caters to users who are looking for a no-frills, first-rate vector signal generator. Its scope of functions has been consistently designed to cover the mainstream applications of vector signal generators. Spe-

cial features such as two-path capability and fading were waived in favor of attractive pricing.

In many aspects, the RF characteristics of the new R&S®SMJ 100A generator come very close to those of the R&S®SMU200A. Featuring an SSB phase noise of typically  $-133$  dBc (1 GHz carrier frequency, 20 kHz carrier offset, 1 Hz measurement bandwidth) and a wideband noise of  $-153$  dBc at 1 GHz, the R&S®SMJ 100A redefines the upper medium segment.

With a 3GPP signal (test model 1, 64 DPCHs), for example, these basic characteristics allow the new generator to achieve typical ACLR values of 69 dB

FIG 1 The R&S®SMJ 100A cuts a good figure, not only when testing WLAN cards.



44 309/8

in the first, and of 71 dB in the second adjacent channel – at an outstanding composite EVM of typically 0.5%.

Plus, the generator achieves superb setting times and exceptional level accuracy: With its frequency setting time of <5 ms, the R&S®SMJ100A outperforms most of its competitors. In List mode, a frequency hop takes even less than 450 μs. The R&S®SMJ100A has a level accuracy of <0.7 dB at  $f \leq 3$  GHz, and of <0.9 dB at  $f > 3$  GHz.

### Flexible baseband with all major standards

The R&S®SMJ100A does not compromise on baseband quality: It has embraced the R&S®SMU200A's state-of-the-art baseband generator with a universal coder and arbitrary waveform generator (ARB). The baseband generator is available with an ARB memory depth of 16 Msamples or 64 Msamples.

The tried-and-tested graphical user interface (GUI) is also from the R&S®SMU200A. Owing to the built-in transients recorder, the baseband signal can be displayed in realtime (FIG 3). The R&S®SMJ100A provides nearly all common representations such as I(t), Q(t), constellation or vector diagram plus power spectrum; these are all functions that are particularly useful with complex signals.

Like the R&S®SMU200A, the R&S®SMJ100A can also generate signals for all major mobile radio standards such as GSM/EDGE, 3GPP FDD including HSDPA and CDMA2000®. The GSM/EDGE option allows the R&S®SMJ100A to change modulation between GMSK and 8PSK in realtime; moreover, it provides all common timeslot formats of the standard plus up to eight different timeslot levels.

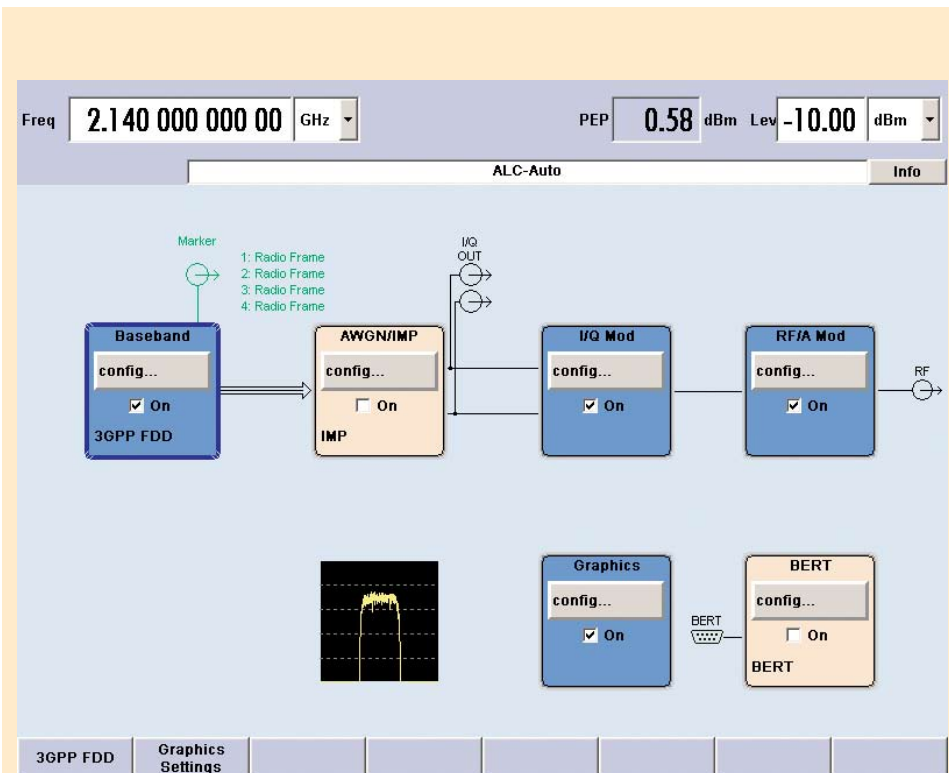

FIG 2 The GUI of the R&S®SMJ100A with the block diagram as the key element.

#### Condensed data of the R&S®SMJ100A

##### Frequency

Frequency range 100 kHz to 3 GHz / 6 GHz  
 Setting time <5 ms  
 Setting time in List mode <450 μs

##### Level

Range -144 dBm to +13 dBm (PEP) [+16 dBm in overrange]  
 Setting time <5 ms

##### Spectral purity (at $f = 1$ GHz)

SSB phase noise (20 kHz carrier offset, 1 Hz measurement bandwidth) typ. -133 dBc

Wideband noise (carrier offset >5 MHz, 1 Hz measurement bandwidth) typ. -153 dBc (CW)  
 typ. -146 dBc (I/Q modulation)

##### ACLR performance

3GPP FDD test model 1, 64 DPCHs typ. 69 dB

##### I/Q bandwidth (RF)

Internal 80 MHz  
 External 200 MHz

##### Arbitrary waveform generator

Memory depth 16 Msamples / 64 Msamples

**Supported standards and digital systems**  
 GSM/EDGE, 3GPP FDD, 3GPP TDD, TD-SCDMA, cdmaOne, CDMA2000®, 1xEV-DO, 1xEV-DV, IEEE 802.11 a/b/g, IEEE 802.16d, Bluetooth™, GPS, AWGN, multicarrier CW, custom digital modulation

► For 3GPP, the R&S®SMJ100A offers up to four code channels in realtime, including channel coding. In the downlink, a maximum of four base stations with 128 code channels each can be simulated, and in the uplink up to 68 mobile stations. The generator is thus able to generate the reference measurement channels in accordance with 3GPP TS25.141 and TS25.104, which are required for tests on base stations and terminals. Moreover, the R&S®SMJ100A supports HSDPA in accordance with the 3GPP Release 6.

The R&S®SMJ100A provides just as much functionality for the CDMA2000® standard where it simulates the physical layer, including channel coding, both in the forward link and the reverse link. Up to four base stations and up to 68 mobile stations can be simulated. The special 1xEV-DV mode for high data rates, also referred to as Radio Configuration 10 (RC 10), is supported as well.

What's more, the generator also covers the standards for wireless data transmission such as WLAN or WiMAX, which

are gaining increasing importance. For example, options for WLAN 802.11 a / b / g and WiMAX 802.16 d are available – and also for GPS, where up to four satellites can be simulated.

Of course, you can also use the generator in combination with the tried-and-tested R&S WinIQSIM™ simulation software; all standards of this software are provided for the R&S®SMJ100A.

### AWGN and differential I/Q outputs

The generator's scope of functions is complemented by the AWGN option (known from the R&S®SMU200A); in addition to additive white Gaussian noise, the R&S®SMJ100A can now generate CW noise signals, which is a useful extra feature for receiver tests. Right from the start, the R&S®SMJ100A also offers differential I/Q outputs as an option. This makes the generator suitable for tests on baseband chips and modules – in addition to its main task as an RF signal source.

### Competent in all fields of application

Powerful, flexible and future-proof, the R&S®SMJ100A is the ideal signal generator for developing mobile radio terminals and modules or WLAN and WiMAX instruments. But also when used in production, the generator cuts an excellent figure, especially if it is only required as a signal source. For example, it can be used for inline tests in mobile radio base station production, where usually neither fading nor noise signals are required.

Another asset that applies to the entire family of generators is their 100% compatibility with regard to remote-control commands. For example, if you use an R&S®SMU200A in R&D, you can easily transfer the remote-control programs specially written for this generator to production, provided the R&S®SMATE200A or the R&S®SMJ100A are used there.

**FIG 3** The built-in transients recorder can sample the baseband signals of the R&S®SMJ100A in realtime and offers various representations such as I/Q diagram, CCDF and constellation diagram (see below).

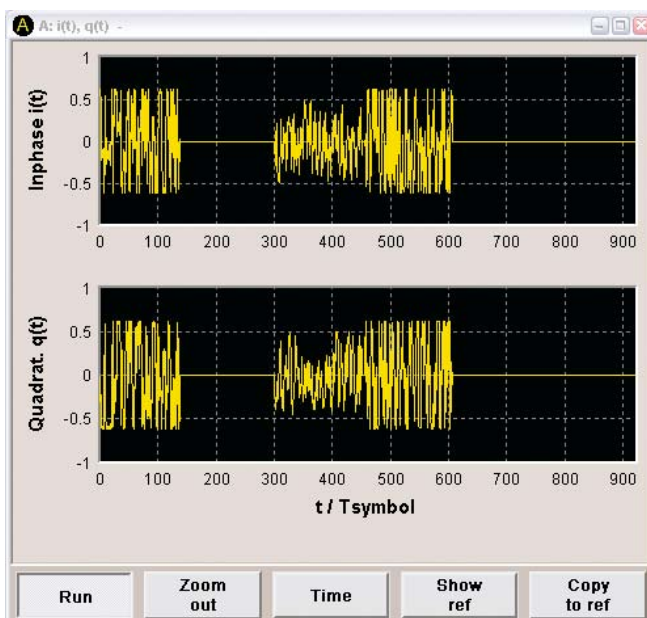



## Summary

Launching the R&S®SMJ100A, Rohde&Schwarz offers a vector signal generator in the upper medium segment that ideally complements the generator family. Together with the R&S®SMU200A and the R&S®SMATE200A, you now have a portfolio of models that cover virtually all conceivable requirements in R&D or in production.

Dr René Desquiotz

More information and data sheet at  
[www.rohde-schwarz.com](http://www.rohde-schwarz.com)  
 (search term: type designation)

### REFERENCES

Vector Signal Generator R&S®SMU200A:  
 The art of signal generation. News from  
 Rohde & Schwarz (2003) No. 180, pp 21–27

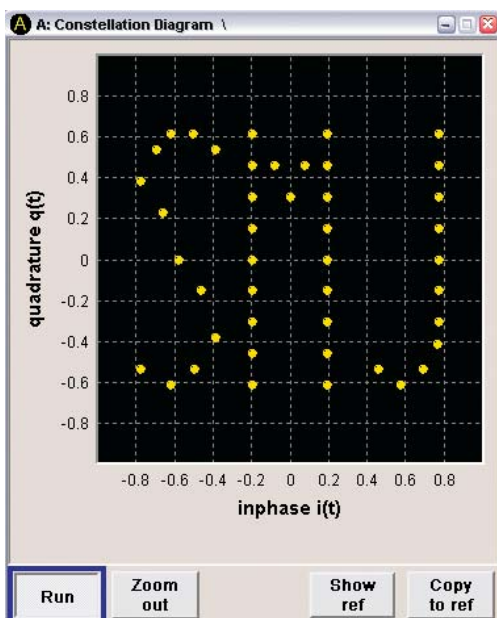

## The generator family at a glance

### The R&S®SMU200A – the artist

- ◆ One or two RF paths
- ◆ Optionally up to two baseband generators
- ◆ Digital addition possible in the baseband with frequency offset and gain
- ◆ Optional fading simulator with up to 40 fading paths
- ◆ Options for low phase noise and high output power
- ◆ Intuitive operating concept with GUI (block diagram)

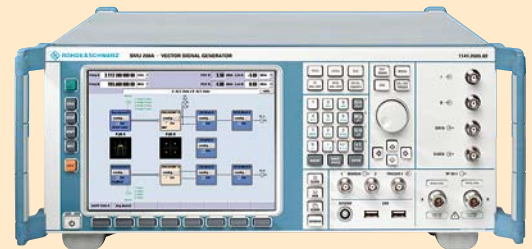

### The R&S®SMATE200A – the workhorse

- ◆ One or two RF paths (6 GHz possible twice)
- ◆ Optionally with up to two baseband generators
- ◆ Digital addition possible in the baseband with frequency offset and gain
- ◆ Options for low phase noise and high output power
- ◆ Flexible hardware List mode with direct addressing

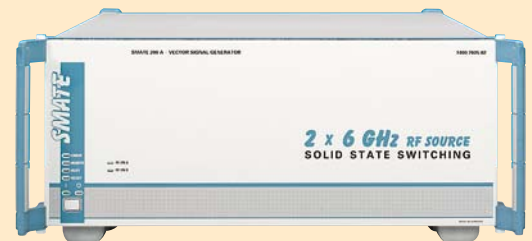

### The R&S®SMJ100A – the allrounder

- ◆ One RF path
- ◆ Optional baseband generator
- ◆ Intuitive operating concept with GUI (block diagram)



## Audio Analyzer R&amp;S®UPV

# Advancing from an audio analyzer to a program-controlled measuring instrument

The new optional Universal Sequence

Controller R&S®UPV-K1 provides the

Audio Analyzer R&S®UPV not only

with a tool for controlling sequences

but also with an entire programming

development environment that makes

the analyzer a versatile measuring

instrument.

## Multitalented analyzer

Like its predecessor, the Audio Analyzer R&S®UPL, the R&S®UPV [\*] allows you to program complex measurement procedures and sequences. In contrast to remote control via the IEC/IEEE bus or a LAN from a remote PC, the controlling program here runs in the background of the measuring instrument. The R&S®UPV, which is based on the Windows® XP Embedded operating system, uses the latest version of Visual Basic.net. The R&S®UPV-K1 option is not only a tool for controlling sequences but also an entire programming development environment including the Microsoft Developer Network (MSDN) help file. A special driver module that is activated during the installation of the option establishes the communication between Visual Basic and the measurement functions of the audio analyzer (1).

The programming commands use SCPI syntax and are identical to commands for all other remote-control interfaces of the R&S®UPV. A Visual Basic program

can thus run internally on the R&S®UPV as well as on an external PC – after exchanging the programming line that activates the driver – and control the audio analyzer via one of its remote-control interfaces such as RS-232-C, GPIB or LAN (2).

Visual Basic provides all modules necessary for convenient programming and result display. The field of application ranges from small automation aids up to complex system controls with user interface and graphical display of the measurement results.

The analyzer's standard function for recording commands makes it considerably easier to create measurement programs. On request, each R&S®UPV manual setting is recorded in the SCPI recording window as a command (3). By using the copy and paste functions, you can directly transfer the command list to the program, thus eliminating syntax errors.

The main applications are automating continuously recurring measurement tasks and implementing complex measurement procedures that are not available on the audio analyzer as independent measurement functions, e. g. acoustic measurements on mobile phones with a sequence of measurements, complex calculations in accordance with the mobile radio standards and result display with PASS/FAIL information.

Even if you have no experience in programming, you will soon be able to easily create executable programs. Measurement examples and extensive help functions are provided, helping you to



44 176/4

get a quick start. In addition to the internal driver, used for communication with the R&S®UPV, no further calls or modules are required. Programs originally written for external remote control can therefore be easily integrated into the analyzer.

Since the SCPI commands of the R&S®UPV are largely identical or compatible to the commands of its predecessor, the R&S®UPL, programs written for the R&S®UPL in Visual Basic can, after minimal modifications, also be run internally on the R&S®UPV.

The Universal Sequence Controller R&S®UPV-K1 turns the Audio Analyzer R&S®UPV into a versatile measuring instrument that can do a lot more than just measure audio parameters. At a keystroke, the R&S®UPV not only controls all measurement sequences, calculates the results and displays them in any desired form (4), but also generates an entire measurement report, if necessary.

Tilman Betz

1

```

Private Sub Form1_Load(ByVal eventSender As System.Object, ByVal eventArgs As System.EventArgs) Handles MyBase.Load
    Dim UPV As New UPx.Application ' include UPV driver
    UPV.InitTCP("localhost") ' connect UPV

    ' initialize sweep values
    Fstart.Text = "100"
    Fstop.Text = "10000"
    Steps.Text = "30"
    Level.Text = "0.1"
    Upper.Text = "10"
  
```

2

```

UPV.Write("*rst;*wai") ' preset UPV
UPV.Write("OUTP:CHAN CH1") ' set generator channel 1
UPV.Write("INP:CHAN CH1") ' set analyzer channel 1
UPV.Write("SOUR:SWE:CONT ASW")
UPV.Write("SENS:FUNC:APER:MODE GENT") ' set meas time GENTRACK
UPV.Write("SENS2:FUNC OFF") ' switch input disp off
UPV.Write("SENS3:FUNC OFF") ' switch frequency off
  
```

3

```

SOURce:FUNCTION SIN
SOURce:FREquency 1000 HZ
INSTrument2 ANLG
INPut:CHANnel CH2I
INPut:BANDwidth:Mode B80
INPut:TYPE GEN1
INPut:FILTer AWE
SENSe:FUNCTION RMS
SENSe:FUNCTION:FFT:STATe ON
SENSe:FUNCTION:FFT:SIZE S32K
SENSe:FUNCTION:APERture:MODE AUTO
  
```

4

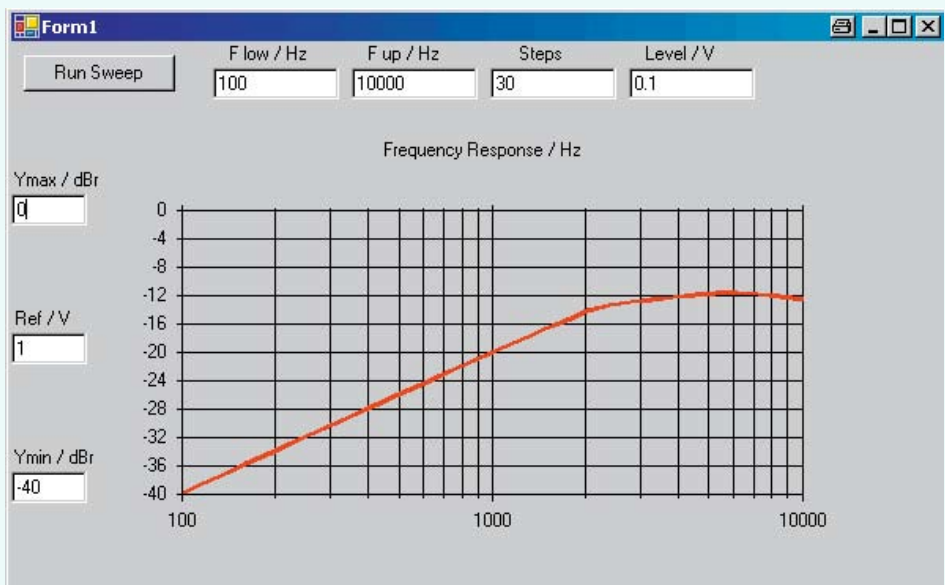

More information and data sheet at  
[www.rohde-schwarz.com](http://www.rohde-schwarz.com)  
 (search term: UPV)



REFERENCES

[\*] Audio Analyzer R&S®UPV: The benchmark in audio analysis. News from Rohde & Schwarz (2004) No. 183, pp 16–20



## Power Meter R&amp;S®NRP

# Fixed Noise: fast power measurement with defined accuracy

Interference such as signal noise, beating and display noise in power measurements can only be effectively eliminated by filters. However, the filters in many commercial power meters are based on classic averaging filter technology, a compromise between measurement speed and high S/N ratio. The R&S®NRP now provides a far better solution: an integrated Fixed Noise filter offering a variety of advantages.

## Filters: indispensable for power measurements

Interference in the signal chain can be critical when measuring lower powers. The inherent noise of the measuring instrument, the modulation of the test signal or beating caused by adjacent carriers are significant impairments [1]. But also the noise of the digital display causing the numeric values to flicker is an additive interference parameter and is independent of the power to be measured.

To minimize such impairment, the R&S®NRP uses an averaging filter as standard, which effectively limits the variations of the measurement results. To obtain a flicker-free display, you must set an averaging filter that is able to handle the low signal level. With a lower measurement limit specified for the Power Sensors R&S®NRP-Z11 / -Z2x yielding excellent 200 pW (–67 dBm) in the Continuous Average mode, you cannot obtain useful results unless the noise is extremely filtered. The reason: the lower the power of the signal to be measured, the higher the relative noise component. To considerably minimize this noise component, the R&S®NRP provides the measurement result by a two-stage averaging process. Depending on the selected measurement mode, you can use either a weighted summation of samples in a fixed time window or the integration of samples over the fixed time window. The measurement result is obtained by averaging the measured values of the last 2N time windows (N = filter length) [2]. Although the measurement time will significantly increase, the dynamic range will be widened by a sizeable 15 dB if the filter is optimally set.

With the following rule of thumb you can roughly estimate the ratio between averaging filtering and measurement time: If the noise is reduced by a factor of 10, the measurement time will be increased by a factor of 100 [3]. For this reason it is quite important to consider what matters more: a flicker-free display or a high measurement speed.

## Normal – the conventional filter mode in the R&S®NRP

The Normal filter mode is based on a complex, intelligent automatic filter function that can determine the power value as exactly as possible. The automatic filter function gradually adapts the filter value if the powers become lower and lower. If you want to measure close to the inherent noise of the sensor, the measurement time is shorter than with conventional filters. If the measurement time is more important, as is often the case in production, you can manually set the filter in such a way that the short measurement time required will be obtained. Low powers in the vicinity of the inherent noise of the sensor may clearly differ from the expected measurement value, since the inherent noise component of the sensor may play a major role and overlap the signal. The drawback of conventional averaging filters is that you can hardly estimate the permissible noise component, which may be of vital importance during fast measurements. And this is where the R&S®NRP's Fixed Noise filter makes your life a lot easier.

## Fixed Noise makes estimating the inherent noise component much simpler

The Fixed Noise filter is a novelty in the world of power meters. In the R&S®NRP,

More information and data sheet at  
[www.rohde-schwarz.com](http://www.rohde-schwarz.com)  
 (search term: NRP)

#### REFERENCES

- [1] Voltage and Power Measurements: Fundamentals, Definitions, Products. PD 757.0835, Rohde & Schwarz 1999
- [2] Operating manual on Power Meter R&S®NRP
- [3] Data sheet on Power Meter R&S®NRP

it is offered in addition to the Normal filter. Its operational principle is based on the fact that a noise component set by the user – this value is entered as “Noise Content” in the R&S®NRP – will be allowed for the measurement. The time required for filtering has to be such that the inherent noise of the sensor (two standard deviations) will not exceed the value set in Noise Content. Imagine that two threshold values define a maximum permissible width and that the inherent noise of the power sensor must be within this width before a measurement result is output (FIG 1). The clear advantage of this method is that you can determine the permissible threshold range for the noise still acceptable from your point of view. The power meter continues averaging until this criterion is fulfilled. To avoid very long filter settling times at low powers, the filter length in the R&S®NRP can be limited with the parameter “Max Settling Time”. This parameter is used as termination criterion for the measurement. If, in case of very low powers, the inherent noise component of the sensor cannot fall below the specified threshold value, the measurement is terminated after Max Settling Time has been reached and the current power value is output. This is indicated by S/N on the R&S®NRP display. FIG 2 shows the differences of the filters in the R&S®NRP with reference to the influence of the noise component on the measurement and the measurement time.

### Special advantages in remote control mode

The Fixed Noise mode is unbeatable, especially if the power meter is operated by remote control. The practicability of this mode becomes clear when you have to estimate the degree of permissible inherent noise during a measurement. Elaborate calculations or trying out the correct averaging filter are no longer

necessary. You can optimally set the power meter manually or by remote control in next to no time. In production, you can thus easily program the R&S®NRP via remote control so that it responds to a short measurement time. Just define a maximum permissible noise as measurement criterion. If a higher inherent noise component of the sensor is permissible, the measurement time can be significantly reduced and the throughput in production considerably increased.

You will discover further advantages if you also start dealing with measurement uncertainties and measurement errors in power measurement. Data sheets provide correction values for a wide variety of cases and allow you to estimate measurement uncertainties and measurement errors. The R&S®NRP will definitely support you in this respect, for it will help you to define the deviations in the Fixed Noise mode yourself.

Dr Markus Banerjee

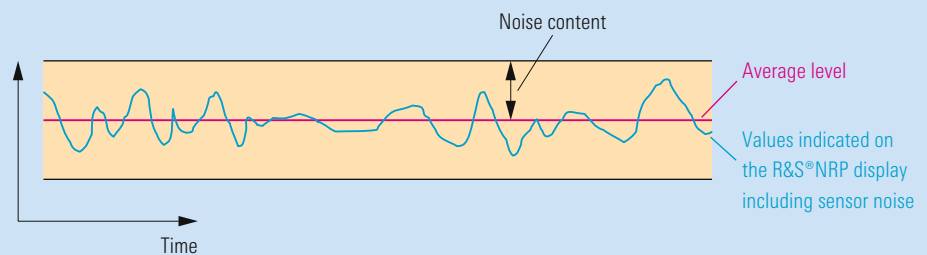

**FIG 1** The noise content in the R&S®NRP defines the threshold ranges of the permissible inherent noise component of the sensor.

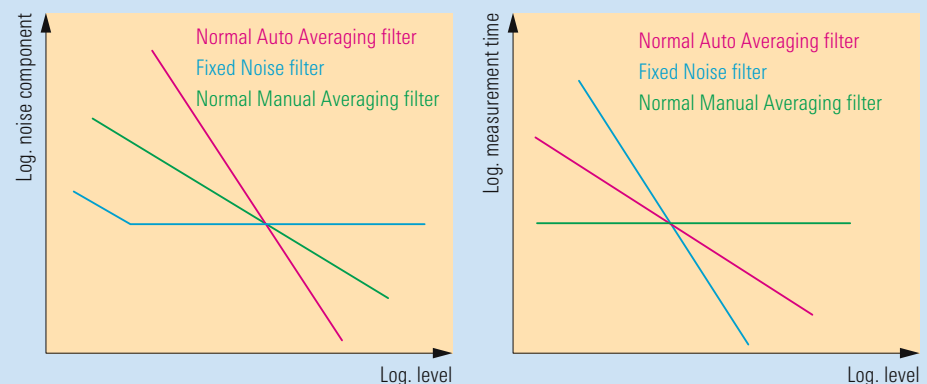

**FIG 2** Influence of the Normal and Fixed Noise filters. You can clearly see the advantages of the Fixed Noise filter with respect to noise component for lower powers. The advantages of the filter with respect to measurement time are also obvious.

## EMC Measurement Software R&amp;S®EMC32-W+

# EMC measurements on mobile radio terminals

The new module R&S®EMC32-W+ extends tried-and-tested EMC

Measurement Software R&S®EMC32

by EMC measurement methods, which are typically used for mobile phones and other wireless communications terminals in accordance with the ETSI families of standards

EN 300607 and EN 301489. One of the instruments controllable with the software is the Universal Radio Communication Tester R&S®CMU200, for which a driver is available. This new module thus implements the essential functions of the R&S®ES-K1 and R&S®EMS-K1 predecessor software packages for performing measurements on mobile phones.

## Electromagnetic immunity: audio breakthrough

The ETSI family of standards EN 301489 describes the procedures for assessing the electromagnetic immunity of mobile radio terminals. The interference fields to be created correspond to those defined in the generic standards EN 61000-4-3 and -6. The measured variables (EUT monitoring, FIGs 1 and 2) to be observed, however, are specific for this EUT family and can now also be evaluated with EMC Measurement Software R&S®EMC32-W+:

- ◆ The 1 kHz AF level demodulated on the loudspeaker of the headset (audio breakthrough downlink)
- ◆ The 1 kHz AF level coupled into the microphone (audio breakthrough uplink)
- ◆ The bit error ratio of the digital radio link (for GSM phones replaced by the RXQUAL parameter)

If a measured value exceeds the permissible limit, the standard describes a method used to assess whether this EUT behavior only occurs in a narrowband frequency range or if it is broadband. For this purpose, the interfering frequency

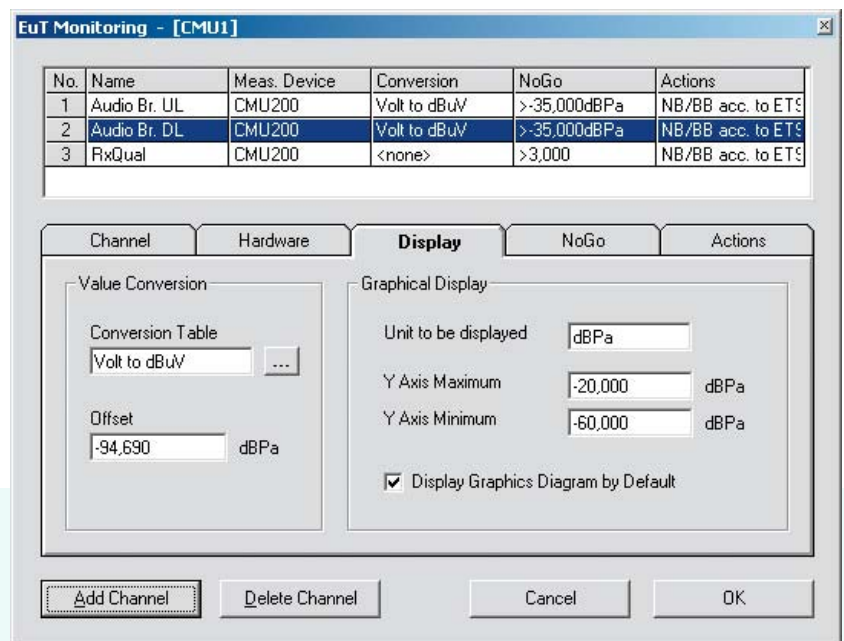

**FIG 1** Definition of EUT monitoring for performing an EMS measurement on mobile phones. All three parameters are measured with the R&S®CMU200. Both audio analyzers of the radiocommunication tester are used to perform a parallel measurement of the two AF levels. A driver for the Audio Analyzer R&S®UPL is available as an alternative.



is reduced and increased by defined offsets and the measurement is repeated again. The software automatically shifts the frequency and indicates in the result table whether the effect is narrowband or broadband.

The measured AF levels are referenced to the reference levels measured before the actual measurement at defined useful levels. R&S®EMC32-W+ supports the recording of these reference levels with the new test function "Audio Breakthrough Calibration" (FIG 3).

### Spurious emissions

The ETSI family of standards EN301489 also describes EMI measurements on mobile phones. The test methods are in line with the basic EMC publications

EN 55022 and can be implemented with Software R&S®EMC32-E+ [1, 2], which is already on the market. An innovation is the integration of the Universal Radio Communication Tester R&S®CMU200, which ensures that the radio link to the EUT is maintained throughout the test.

With R&S®EMC32-W+, you can also measure the spurious emissions of GSM telephones in compliance with the ETSI standard EN300607-1 governing conformance tests. For other mobile radio systems, similar methods are described in the relevant ETSI standards. You then determine the maximum of the effective radiated power (ERP) that is unintentionally emitted by the EUT outside its useful channel. The software supports the common positioning devices (azimuth  $\Phi$ ) for radiated spurious emissions but also allows you to define an additional posi-

tioning device (elevation  $\Theta$ ) to tilt the mobile phone (FIG 4). The elevation parameter is then included in the test sequence definition in order to find the maximum emission (FIG 5).

In contrast to common EMC standards, which stipulate the use of the quasi-peak detector and EMI filters with 6 dB bandwidths, ETSI EN 300 607-1 calls for maxima (peak detector) to be measured with 3 dB analyzer bandwidth. To meet this requirement, the software is equipped with a special driver that controls the EMI Test Receiver R&S®ESIB in such a way that the scans and individual measurements usually running in the receiver mode are emulated by zero span measurements in the analyzer mode.

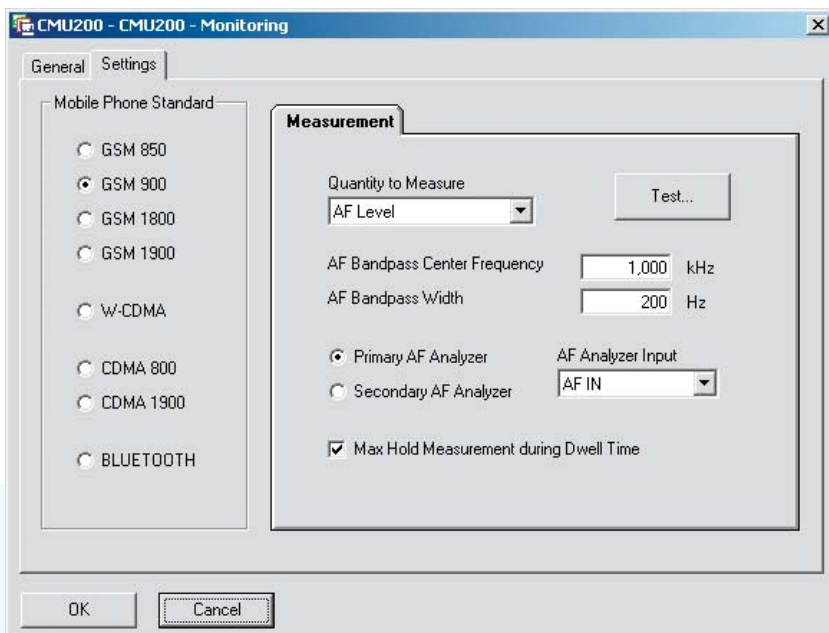

**FIG 2** Entry window for programming the R&S®CMU200 for measuring an AF level. Marking the check box "Max Hold Measurement during Dwell Time" results in a fast cyclical measurement of the level in order to determine the highest demodulated level before the noise cancellation algorithms of the mobile phone become active.

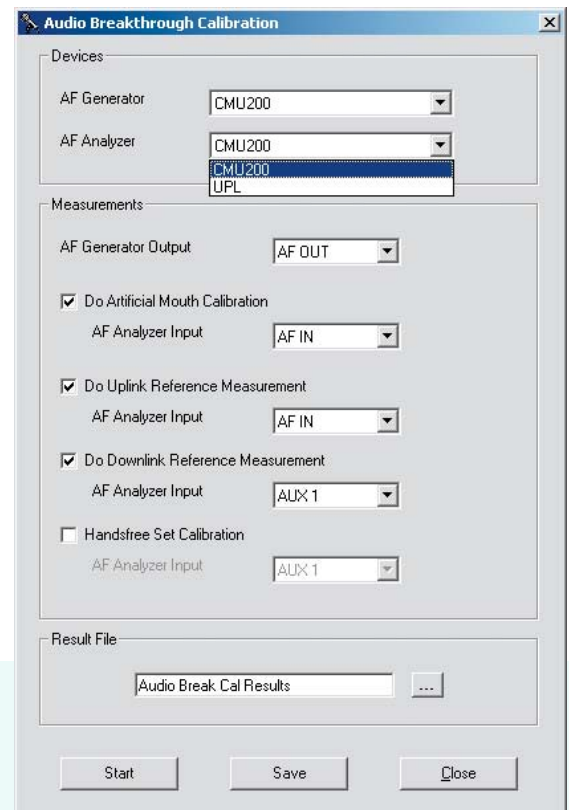

**FIG 3** Dialog field for recording the AF reference levels. The method requires manual intervention of the user. The software provides the user with essential information.

► The standard specifies the measurement of spurious emissions as substitution measurement: You first have to find the direction in which the EUT sends its maximum emission and then replace the EUT by a generator and a standard dipole. Subsequently, you have to set the generator so that the same value is measured. Since the user often has to intervene, it is difficult to automate this method. A precalibration of the test path is therefore permissible. The attenuation of the path is recorded in the anechoic chamber using a calibrated transmitting antenna. When the measurement is made, the measured power will then be corrected by this attenuation, allowing the power actually radiated by the EUT to be calculated.

When measuring spurious emissions, you have to take into account that the available mobile radio carriers, especially the BCCH, are also received by the measuring equipment. They may overload the receiver input and result in intermodulation. You therefore use tunable band-stop filters, which can suppress a very

narrow frequency band (ideally a GSM channel of 200 kHz) with a high attenuation (>40 dB). Although it is quite difficult to tune these filters, which normally have at least six poles, R&S®EMC32-W+ supports you by offering the new mode "Notch Filter Tuning" in the calibration configuration for system paths.

## Summary

EMC Measurement Software R&S®EMC32-W+ includes the essential functions offered by the tried-and-tested software packages R&S®ES-K1 and R&S®EMS-K1 for performing measurements on mobile phones. This underlines the flexibility and upward compatibility of the R&S®EMC32 platform, which features a consistently modular structure and an adaptable device driver concept. The software now supports all methods for securing the EMC of mobile phones. These methods are implemented at many locations using Rohde & Schwarz systems.

Juan-Angel Antón; Ulrich Konietzko

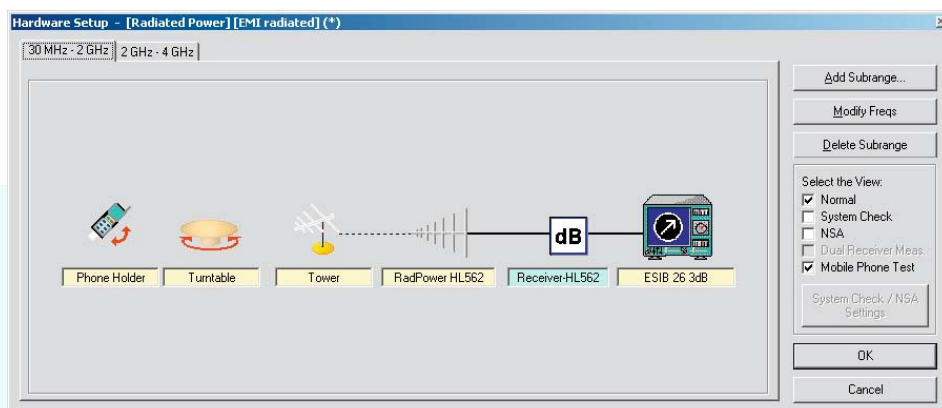

FIG 4 Hardware setup for measuring radiated spurious emission with tilting equipment for mobile phones.

**More information at**  
[www.rohde-schwarz.com](http://www.rohde-schwarz.com)  
 (search term: EMC32)

REFERENCES

[1] EMI Measurement Software R&S®EMC32-E+: All-purpose software for complete EMI measurements. News from Rohde & Schwarz No. 184 (2004), pp 42–45

[2] EMC Test Software R&S®EMC32-A: Versatile EMS and EMI measurements for the automobile sector. News from Rohde & Schwarz No. 178 (2003), pp 36–40

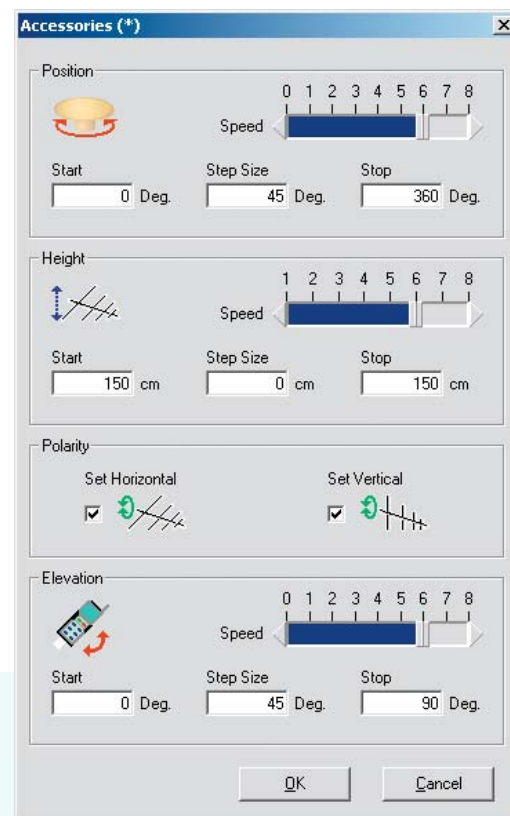
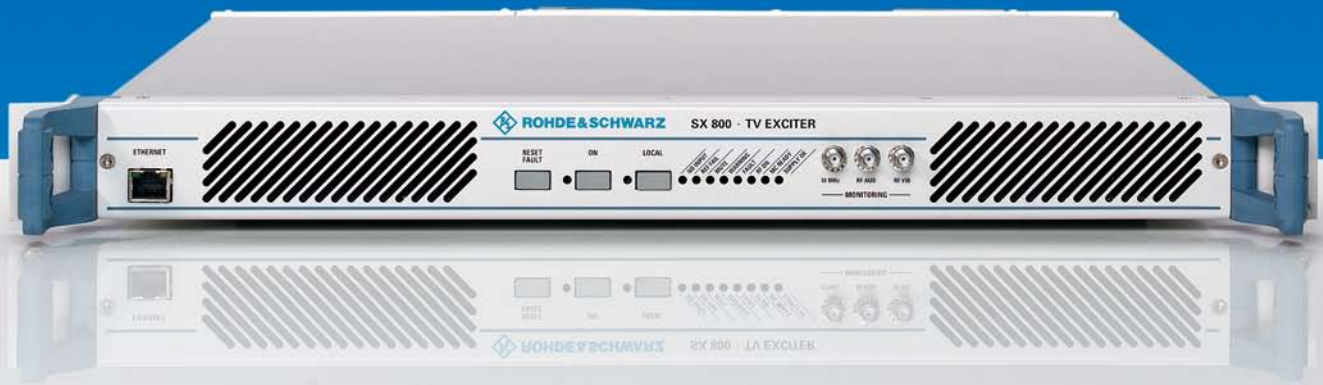

FIG 5 Parameterization of accessories for positioning the EUT and the test antenna. In addition, priority levels can be assigned to each accessory to optimize the positioning order with regard to achieving a short measurement time.



44318/1

FIG 1 Occupies only one height unit: the new multistandard Exciter R&S®Sx800.

### Exciter R&S®Sx800

## Multistandard exciter for ATV and DTV

State-of-the art technology makes it possible: The new multistandard Exciter R&S®Sx800 is housed in a box of only one height unit and includes complete signal processing functionality ranging from the video/audio input signal (analog TV) and the transport stream (digital TV) to standard-compliant RF output signals.

### Compact and powerful

The Exciter R&S®Sx800 (FIG 1) has been designed for use in the new Transmitter Family R&S®Nx8000 [\*]. Like its predecessor R&S®Sx700, the exciter of just one height unit is based on a modular concept that ensures utmost safety of investment. It mainly consists of the input interface, mainboard and RF interface modules (FIG 2).

### Input interfaces for analog or digital TV

The exciter is equipped with the corresponding interfaces depending on the relevant operating mode – ATV or DTV. You can easily upgrade the exciter from analog to digital standard at any time, since the required software has already been installed.

The input interface for ATV converts the video and audio signals required for further internal processing into digital signals. It optionally handles the NICAM signal processing and codes and modulates the NICAM sound subcarrier. The operating modes “analog audio”, “NICAM DATA 728” and “NICAM sub-carrier” are supported.

For DTV, the R&S®Sx800 with four ASI inputs (DVB-T/-H) or two inputs in line with SMPTE-310M (ATSC) can be universally used for all operating modes of the following standards: DVB-T/-H and ATSC (including ATSC DX for SFN).

With DTV, the input interface monitors the applied signals with respect to packet synchronization and data rate. The input data buffer eliminates jitter and frequency offsets of the distribution network. In multifrequency networks (MFNs), the input data rate is adapted to the selected DVB-T mode including



# Exciter A

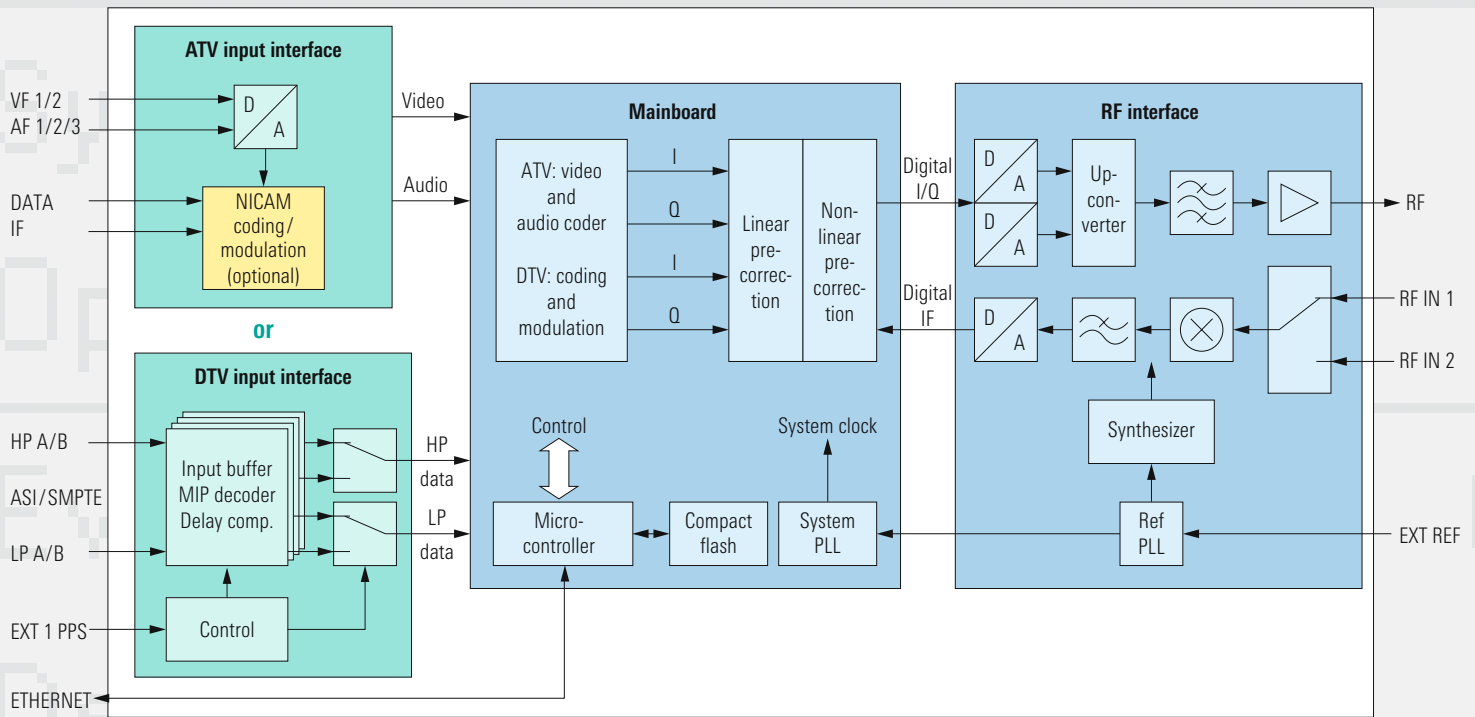

FIG 2 Structure of the multistandard Exciter R&S®Sx800.

	Manual	Selector	TPS
Constellation	QPSK	Man	QPSK
FFT Length	2 K	TPS	2 K
Hierarchy	alpha=1	Man	alpha=2
Guard Interval	1/4	Man	1/4
Code Rate	1/2		

Edit: Manual	
1/4	
1/8	
1/16	
1/32	

FIG 3 Operation of exciter via the R&S NetCCU®800.

### Condensed data of the R&S®SX800

ATV standards	B/G, D/K, M/N, I
Color transmission	PAL, SECAM, NTSC
Sound transmission	IRT dual sound, FM single sound, FM single sound with NICAM 728 (optional), BTSC
DTV standards	DVB-T/H in line with EN 300 744 ATSC (8VSB) in line with Doc.A/53 FCC band I, III, IV, V
Frequency range	
Output power	ATV: +20 dBm sync peak power DTV: +13 dBm RMS

- the necessary PCR (program clock reference) correction. Every path has its own TS 101 191-compliant MIP decoder that is able to automatically recognize the operating mode. When operated in single-frequency networks (SFNs), the MIP decoders also provide information on the time-relevant synchronization of input signals and thus allow automatic and seamless input signal switching. Redundant input signals can be applied but the output signal will not be interrupted during switchover.

### Signal processing on the mainboard

With ATV selected, the mainboard processes the signals digitized by the input interface in accordance with the relevant TV standard. Digital signal processing ensures highest stability and thus allows easy precorrection of transmit signals.

With DTV selected, coding and modulation are in line with EN 300 744 (DVB-T/H) or Doc. A/53 FCC (ATSC). Digital filters and algorithms with relevant resolution ensure top quality of the generated I/Q signals applied to the subsequent precorrector. Linear precorrection compensates group delay and frequency response caused by power filters in the RF path, for example. Nonlinear precorrection compensates distortion products caused in the amplifiers.

With digital precorrection applied here, you can reproduce the results at any time. An automatic/adaptive precorrection function can be supplied as an option for digital operation.

### Special features of the Exciter R&S®Sx800

- ◆ Suitable for use in single-frequency and multifrequency networks
- ◆ Hierarchical modulation
- ◆ Seamless input switching
- ◆ MIP monitoring
- ◆ All ASI modes
- ◆ SMPT-310M
- ◆ DVB-H, DVB-T, ATSC
- ◆ All analog TV standards (except for L)
- ◆ Integrated linear and nonlinear precorrection
- ◆ Optional automatic precorrection (DTV), NICAM

### RF interfaces

The RF interface converts digital I/Q signals into analog baseband signals. The modulator that follows generates the readily modulated signal via double conversion. This signal is then filtered and amplified. Since direct modulation and conversion are coupled, adjustments are no longer required when the frequency is changed. Since switchable attenuator pads are provided at the output, you can optimally adapt the output level to subsequent amplifiers.

The synthesizer, which can of course be coupled to an external reference frequency, provides the required mixer frequencies. The high quality of the reference oscillator ensures that the frequency stability in the SFNs remains unchanged even if the external reference fails. The RF interface optionally contains the demodulator path, which processes the amplified or filtered RF signal for signal analysis in case of automatic/adaptive precorrection. The exciter has two inputs at which the signals can be tapped ahead of or after the power filter.

### Control

A powerful microcontroller controls and configures the R&S®Sx800. It initializes the hardware from a compact flash memory that comprises the complete software and firmware as well as all settings. This concept simplifies the configuration of a replacing unit: The memory is taken from the exciter to be replaced and is inserted into the replacing unit. The replacing unit runs with the identical software version and the same settings after switch-on.

The controller in the transmitter communicates with the R&S NetCCU®800 via Ethernet interfaces and, if required, with a local PC. In the transmitter, the exciter can be operated via Ethernet using the CCU (FIG 3). Alternatively, local and remote control is possible via the web browser of a PC. A Java-based web server is available in the exciter. It makes software installations on the PC superfluous.

Cornelius Heinemann

More information and data sheet at  
[www.rohde-schwarz.com](http://www.rohde-schwarz.com)

#### REFERENCES

- [\*] UHF TV Transmitter R&S®NH / NV8200: Air-cooled UHF/VHF TV transmitters for the medium-power segment. News from Rohde & Schwarz (2005) No. 185, pp 40–42

Family of VHF FM Transmitters R&S®NR8200

## Compact, air-cooled transmitters for 2.5 kW to 30 kW

The new air-cooled R&S®NR8200 FM transmitter generation (FIG 1) covers a power range from 2.5 kW to 30 kW. All transmitters feature outstanding technical parameters, an optimum cost/benefit ratio, extremely high reliability plus ease of servicing. They are equipped with the new digital state-of-the-art Exciter R&S®SU 800 with integrated AES/EBU interface. The compact air-cooled models with only 800 mm rack depth provide an output power of up to 15 kW in a 19" rack.



FIG 1 The new, compact FM transmitters, with only 800 mm rack depth, provide up to 15 kW output power in a 19" rack.

### Powerful FM transmitters with excellent specifications

The new transmitters include the following components:

- ◆ Exciter R&S®SU800
- ◆ Power Amplifier R&S®VU825
- ◆ Transmitter rack with cooling system
- ◆ Power combiner
- ◆ Power distribution
- ◆ Control Unit R&S NetCCU®800

### Exciter R&S®SU 800

The synthesizer-based digital Exciter R&S®SU 800 generates a frequency-modulated RF signal in the range from 87.5 MHz to 108 MHz. The use of state-of-the-art circuitry allows the R&S®SU 800 to be accommodated in a housing of only one height unit. Both analog AF signals and digital signals in line with bit-serial AES/EBU protocol can be processed. Left/right, MPX, RDS

or SCA signals can be used as modulation signals. Eight preset channels are available, and the settings for the active channel can be saved power-failure-proof in each of them.

### Control Unit R&S NetCCU®800

The R&S NetCCU®800 transmitter control unit handles both internal and external communication and provides all control functions. It shows the current status of the transmitter system in different languages on a color display. All transmitter and amplifier parameters required for diagnostics can be retrieved locally as well as remotely from anywhere in the world via standard (IP) protocol and standard software (web browser, SNMP). All conventional standby systems, such as exciter standby, (n+1) standby, passive standby and active output standby, can be configured. For the exciter standby and the active output stage standby, no additional control units are necessary.

### Power Amplifier R&S®VU 825

Equipped with the latest MOSFET technology, the R&S®VU 825 power amplifier features excellent efficiency and compact design (FIG 2). Each RF amplifier has its own power supply. They amplify the signal to a power of approx. 2.7 kW. The amplifier modules can be easily replaced during operation without requiring optimization or adjustment.

### Transmitter rack with integrated cooling

A 19" rack (depth 800 mm) is used for all power classes. One rack accommodates up to six amplifier modules. The rack contains two built-in fans that operate in active standby. Various air ducting configurations can be implemented, with cooling air intake from the top, bottom or rear of the transmitter rack, and exhaust air discharge toward the top or bottom. Each amplifier module contains an optimized, highly efficient heat sink. This in conjunction with the elaborate cooling concept ensures effective cooling with only small amounts of air. This in turn considerably reduces the cooling system's power consumption and noise generation.

An innovative, nearly wireless power distribution system simplifies assembly and servicing. The frequency-response-compensated directional coupler integrated in the transmitter and built-in lightning protection round out the R&S®NR 8200 transmitter family.



**FIG 2** The R&S VU825 is modular in design and includes four identical 700 W base modules that are controlled by a 64 W preamplifier.

The transmitters comply with the R & TTE Directive 1999/5/EU and meet the standards EN 60215 for personal safety, EN 301489-1 and EN 301489-11 for EMC, as well as EN 302018-1 and EN 302018-2 for RF requirements. The R&S®NR 8200 transmitter family complies with the relevant standard specifications of Deutsche Telekom as well as of the two broadcasting companies ARD (Germany) and ORF (Austria). The necessary certifications will soon be carried out. FIG 3 provides an overview of the individual models.

Reinhard Kasueske; Elke Schulze

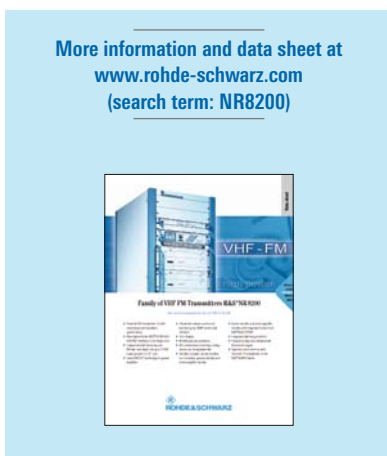

**FIG 3** The most important specifications of the individual models.

	R&S®NR 8202	R&S®NR 8205	R&S®NR 8207	R&S®NR 8210	R&S®NR 8212	R&S®NR 8215	R&S®NR 8220	R&S®NR 8230
<b>Nominal output power</b>	2.5 kW	5 kW	7.5 kW	10 kW	12.5 kW	15 kW	20 kW	30 kW
<b>Number of amplifiers</b>	1	2	3	4	5	6	8	12
<b>Connector</b>	1 5/8" EIA			3 1/8" EIA				
<b>Weight</b>	250 kg	330 kg	380 kg	430 kg	480 kg	550 kg	860 kg	1100 kg
<b>Dimensions (W × H × D)</b>	600 mm × 2000 mm × 800 mm						1200 mm × 2000 mm × 800 mm	



## TV Analyzer R&amp;S®FSH3-TV

# Universal, portable combination of TV analyzer and spectrum analyzer

Mobile measurement and service technicians place high demands on their measuring instruments. Not only are characteristics like size, weight, reliability and rugged design important – another must is a wide variety of measurement functions, precision and a high dynamic range.

The R&S®FSH3-TV offers all these strengths (FIG 1).

## For measurements on TV transmitters or TV cable networks

The TV Analyzer R&S®FSH3-TV combines the measurement capabilities of a TV test receiver with spectrum analyzer capability, despite its extremely small size. Its compact design and low weight make it ideal for portable use in installation, maintenance and servicing of TV transmitters and cable networks. What these fields of application share is working in cramped spaces at changing sites often under adverse climatic conditions.

Since the TV Analyzer R&S®FSH3-TV also has reinforced corners and covered RF connectors, it can withstand occasional rough treatment. A rugged handle and a foldable stand together with a daylight-compatible color display offer you an optimum viewing angle to the analyzer.

The built-in NiMH battery ensuring up to four hours of reliable operation independent of the AC supply supports mobile use of the measuring instrument.



44310/7

**FIG 1**  
The TV Analyzer R&S®FSH3-TV was presented at NAB 2005 where it received three awards. The reason is clear: The innovative instrument can handle a wide variety of applications in the installation, maintenance and servicing of TV transmitters and cable networks.



44310/8

## TV specialist

The TV Analyzer R&S®FSH3-TV offers features and options specially tailored to measurement tasks that have to be mastered by TV cable and transmitter network operators. Measurement frequencies, for example, can be set via supplied TV channel tables.

The TV board (FIG 2) integrated into the base unit offers comprehensive TV measurement functions for analyzing and demodulating analog and digital TV signals. FIG 4 provides an overview of the available TV standards.

The R&S®FSH3-TV normally comes with an RF input and N connector (50 Ω). The Matching Pads R&S®RAZ (50/75 Ω) or R&S®FSH-Z38 are provided to ensure the correct characteristic impedance connection to cable network components or TV antenna systems, for example.

If the analyzer is often used in cable networks, it is advisable to work with the new Preselector R&S®FSHTV-Z60 (FIG 3). This preselector, which is connected ahead of the broadband RF input of the R&S®FSH3-TV, improves the usable dynamic range when measurements have to be made at high channel density. The preselector is simply fastened to the RF input of the analyzer and connected to the base unit via the control cable by which it is fed. The RF input of the preselector is a 75 Ω F connector that can be easily exchanged so that the R&S®FSH3-TV can immediately be used again.

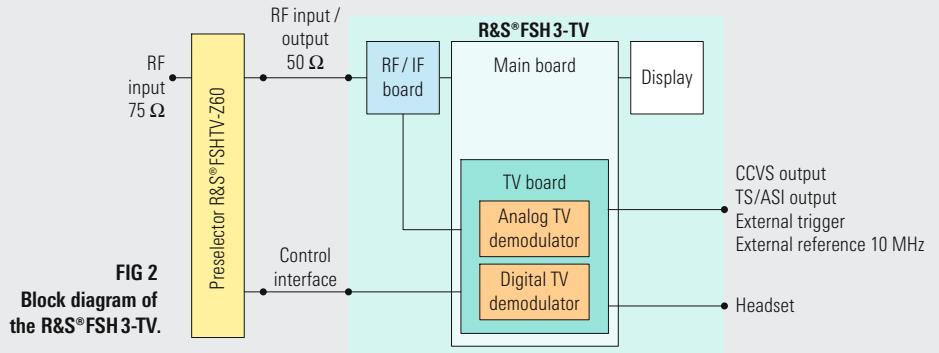

**FIG 2**  
Block diagram of the R&S®FSH3-TV.



**FIG 3**  
Preselector R&S®FSHTV-Z60.

**FIG 4**  
TV standards of the R&S®FSH3-TV.

R&S®FSH3-TV (as standard)	B, G, H, D/K, N, I, L, M/NTSC, M/PAL
R&S®FSHTV-K21 (option)	DVB-C (J.83/A/C), J.83/B
R&S®FSHTV-K22 (option)	ATSC/8VSB

### The most important abbreviations

ATSC/8VSB	Digital terrestrial TV (US standard)
BER	Bit error ratio
C/N	Carrier to noise
CSO	Composite second order
CTB	Composite triple beat
DTV	Digital TV
DVB-C	Digital video broadcast – cable
EVM	Error vector magnitude
MER	Modulation error ratio
TS-ASI	Transport stream – asynchronous serial interface

### ► Analog TV still widely used

Despite continuing digitization, analog TV is still widely used and is sure to endure. The TV Analyzer R&S®FSH3-TV is ready to meet these requirements, since it offers a variety of analog TV measurements as standard for the most common analog TV standards worldwide.

In the Measurement List mode, the analyzer displays the statuses of the vision and sound carriers and measures the S/N ratio of the video signal (FIG 5). The display optimally adapts to the selected TV standard. In the Video Scope mode, the analyzer demodulates the video signal and displays it on the measurement screen in the time domain (FIG 6). Marker functions allow detailed measurements. In the Measurement List and Video Scope modes, the demodulated video signal for controlling by a TV monitor is available at the BNC multifunction connector. You can listen to the demodulated sound signal by using the headphones supplied.

The Carrier Measurements mode precisely measures the vision and sound carriers. The device settings are adapted to the selected TV standard. Another special feature of the R&S®FSH3-TV is a video line trigger that, in the Vision Modulation mode, allows you to measure modulation depth and residual carrier. The measurement screen conveniently displays the vision carrier power of individual video lines.

### Upgradeable for DVB-C and ATSC

You can swiftly and easily upgrade the R&S®FSH3-TV at any time to perform measurements on digital TV signals. The analyzer offers the most important operating parameters of the selected DTV channel at a glance together with parameters such as MER, EVM or BER (FIG 7). The constellation diagram (FIG 8) is important for further analysis of the DTV signal. All parameters and measurement values are displayed in parallel.

The demodulated DTV signal is available at the combined BNC output (here: TS-ASI output) for further processing. You can connect an MPEG-2 transport stream analyzer such as the R&S®DVM 400 from Rohde & Schwarz to make further in-depth measurements.

### Also spectrum specialist

To fully detect the characteristics of a TV transmitter or a cable network system, you must have a number of measurement results in the frequency spectrum in addition to the measurement parameters specifying the quality of a modulated TV signal. The R&S®FSH3-TV therefore offers special settings and test routines, e.g. measurements of the shoulder attenuation (FIG 9), C/N, CSO, CTB or HUM.

### First a specialist, now an allrounder

An extensive range of optional accessories opens up a variety of options to optimally adapt the R&S®FSH3-TV to the task at hand. Various power and directional power sensors as well as the VSWR Bridge and Power Divider R&S®FSH-Z2 are available. With the measurement bridge and the R&S®FSH-B1 option, you can perform distance-to-fault measurements, for example, and detect poor connection points or damaged cables.

You can also store antenna factors in the R&S®FSH3-TV. With a suitable measurement antenna, e.g. the R&S®HE 200 from Rohde & Schwarz, you can make coverage measurements.

### Summary

The TV Analyzer R&S®FSH3-TV is an excellent solution for TV measurement technicians. They can fully rely on a portable, universal and unfailing measuring instrument in installation, maintenance and service. The wide variety of functions from special TV measurements to universal measurements makes the R&S®FSH3-TV a future-proof and efficient investment unrivaled in this compact equipment class.

Werner Dürport





FIG 5 Operating mode ANALOG TV RECEIVER – Measurement List.

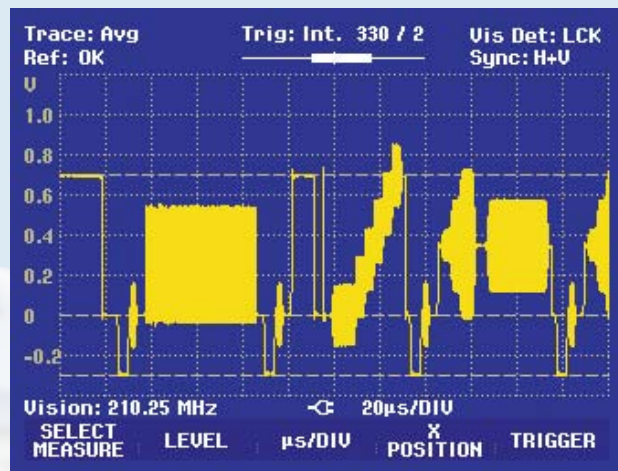

FIG 6 Operating mode ANALOG TV RECEIVER – Video Scope.



FIG 7 Operating mode DIGITAL TV RECEIVER.

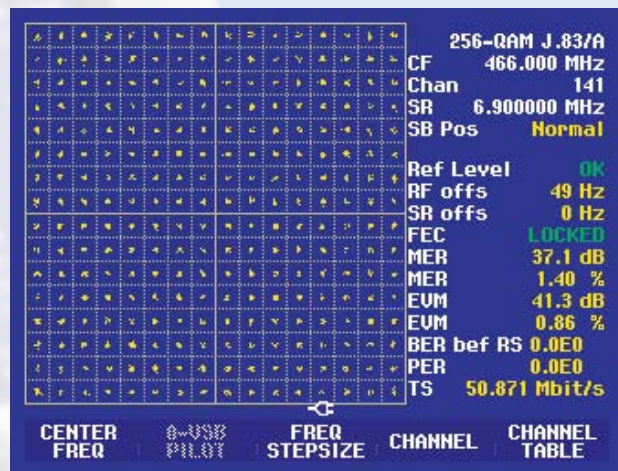

FIG 8 Constellation diagram 256QAM.

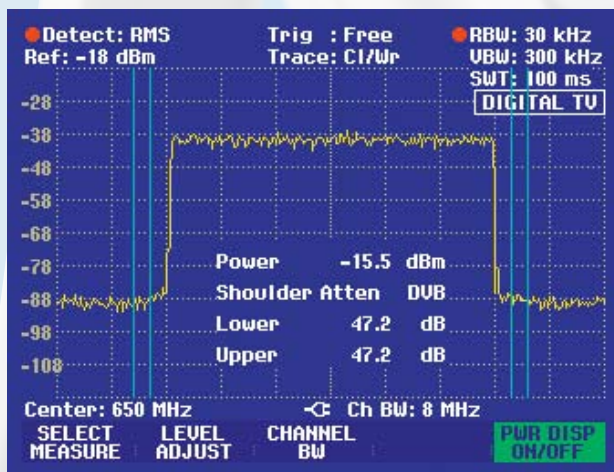

FIG 9 Measurement of shoulder attenuation of DVB-T signal in line with ETSI TR101290.

### Condensed data of the R&S®FSH3-TV

**Digital TV receiver** (option R&S®FSHTV-K21 for QAM, R&S®FSHTV-K22 for 8VSB)

Modulation methods 4 / 16 / 32 / 64 / 128 / 256QAM, 8VSB  
 Bandwidths (depending on standard) 6 MHz, 7 MHz and 8 MHz  
 Symbol rate at QAM / ATSC 2 MHz to 6.999 MHz / 10.762238 MHz  
 Inherent MER (equalizer ON) >35 dB

#### Analog TV receiver

Standards B, G, H, D, K, I, L, M, N,  
 Sound standards IRT-A2, **NICAM**, **BTSC**, EIA-J  
 Video bandwidths depending on standard  
 Inherent S/N video, weighted to CCIR Rec. 567 >50 dB

#### Spectrum analyzer

Frequency range 100 kHz to 3 GHz  
 Resolution bandwidths 100 Hz to 1 MHz  
 Video bandwidths 10 Hz to 3 MHz  
 Displayed average noise level typ. -135 dBm (100 Hz)  
 TOI typ. 13 dBm  
 SSB phase noise <-100 dBc (1 Hz) at 100 kHz from carrier  
 Sweep time (span = 0 Hz) 1 ms to 100 s  
 Detectors Sample, Max / Min Peak, Auto Peak, RMS  
 Level measurement uncertainty <1.5 dB, typ. 0.5 dB  
 Reference level -80 dBm to +20 dBm

#### General data

Dimensions (W x H x D) 170 mm x 120 mm x 270 mm  
 Weight 2.7 kg

More information and data sheet at  
[www.rohde-schwarz.com](http://www.rohde-schwarz.com)  
 (search term: FSH3-TV)



## MPEG-2 Monitoring System R&amp;S®DVM

# Video decoder, DVB-H analysis and other novelties

The R&S®DVM family of MPEG-2 monitoring systems, which features comprehensive monitoring and analyzer functions, is becoming even more versatile. A completely new feature is a powerful streaming interface that transfers individual transport stream elements to external applications for display or analysis. A software video decoder (media player) offers functions to view video and

DVB-H contents.

## New functions – applications in practice

With the new streaming interface, you can output selected transport stream elements in realtime via the network interface of the analyzer board in the R&S®DVM for processing by a selected replay or analysis application. Depending on the type of application, you can run these applications on the R&S®DVM controller or – owing to an integrated router – even on any separate PC in the network. This flexible concept offers a variety of new applications:

- ◆ Live replay of video elementary streams via the software video decoder (media player)
- ◆ Video elementary stream analysis
- ◆ Analysis and replay of DVB-H contents
- ◆ Write to File function to extract transport stream elements and to store them on hard disk

## Media player

The media player software can replay a video elementary stream selected on the R&S®DVM user interface live via the internal controller or via an external PC in the network (FIG 1).

If the media player runs on an R&S®DVM 100 or R&S®DVM 400, it decodes the video elementary streams in SDTV resolution. If the media player runs on an external PC connected to a network, you can even decode HDTV video elementary streams in realtime, provided that the computing power and network connection are sufficient.

## Elementary stream analyzer

The tried-and-tested Elementary Stream Analyzer® software can analyze the MPEG-2 video elementary streams displayed by the R&S®DVM. You only have to select the desired video elementary stream on the user interface and start the analysis. The software, which is available as option R&S®DV-ESA for the monitoring systems, clearly displays the structure of a video elementary stream, consisting of sequences, groups and pictures, in a tree diagram and informs you about the contents of the corresponding headers (FIG 2). The software also displays the contents of individual macro blocks in graphical and numeric form and analyzes their motion vectors. Detailed macro block statistics and a picture detector complement the system functions of the elementary stream analyzer.

## DVB-H time slice analyzer / MPE-FEC analyzer

The option Data Broadcast Analysis R&S®DVM-K11 contains the DVB-H time slice analyzer, which extracts and analyzes DVB-H contents in realtime. To replay H.264 and other video contents contained in the IP datagrams of a DVB-H service live, the time slice analyzer can stream them to the media player. You can conveniently select the DVB-H stream to be analyzed or replayed from the user interface of the R&S®DVM and start the analysis or replay.

The analysis determines the number of errors before and after FEC decoding and creates exact statistics about the timing and structure of a DVB-H burst (FIG 3).

More information, data sheets and flyers about the R&S®DVM family at [www.rohde-schwarz.com](http://www.rohde-schwarz.com) (search term: DVM)

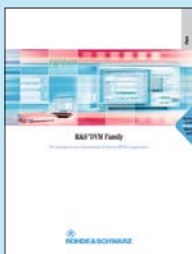

R&S®DVM family flyer

FIG 1  
Video elementary streams  
can be replayed live with  
the media player.

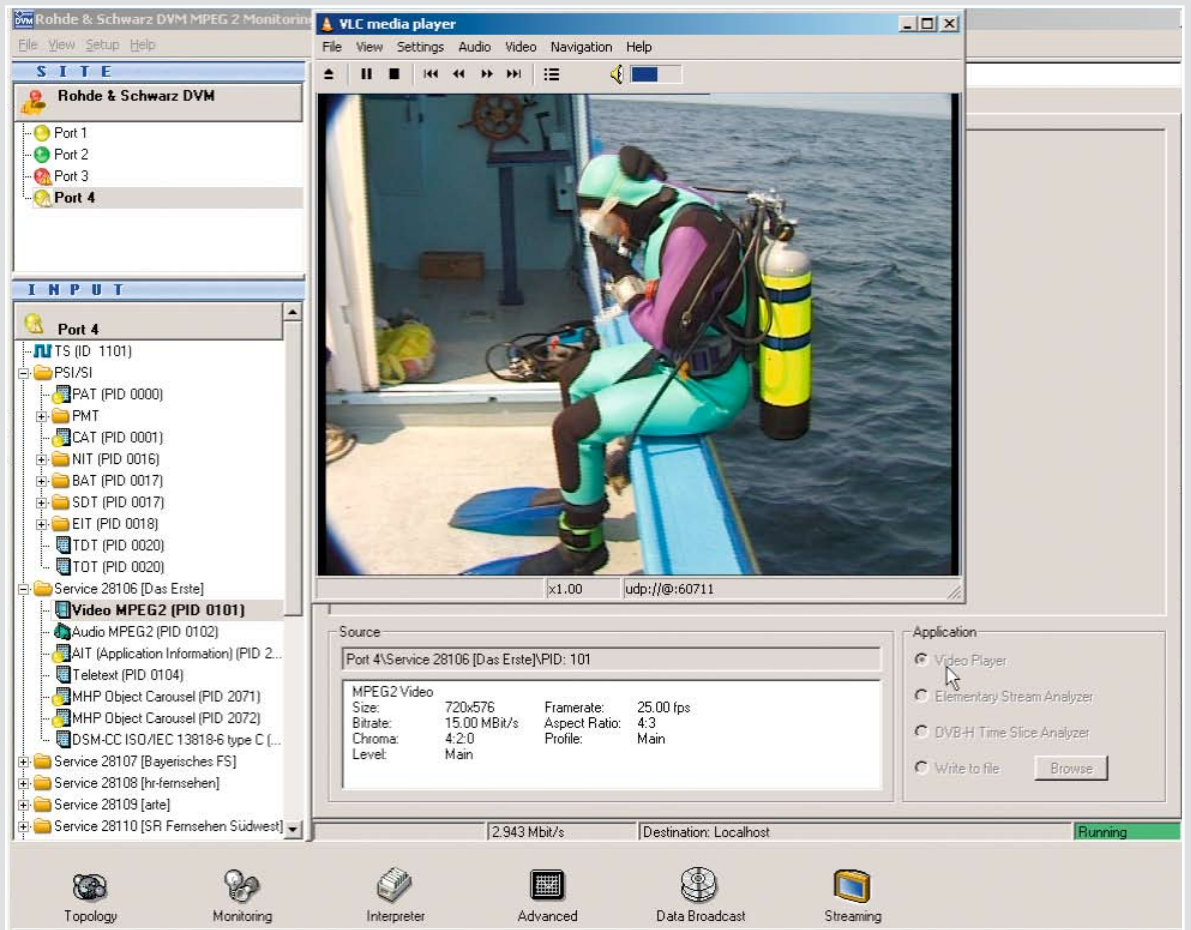
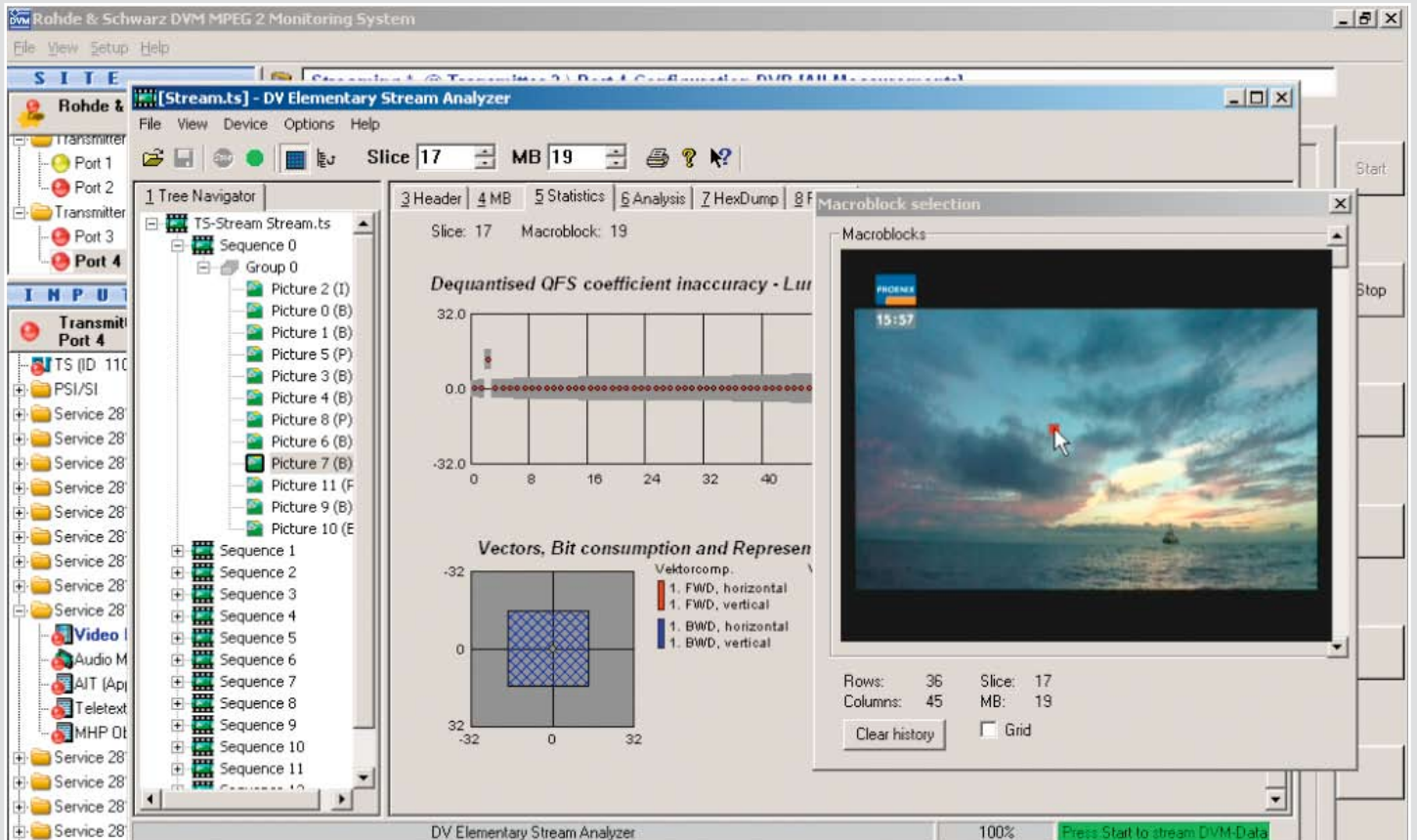

FIG 2 Convenient analysis of a video elementary stream with Elementary Stream Analyzer®.



## ► Write to File

The Write to File application allows you to store transport stream elements in realtime on the local hard disk of the controller in the R&S®DVM. The maximum recording time for the transport stream element selected on the user interface is limited only by the amount of free memory space available on the local hard disk. You can thus filter packets with a certain PID from a transport stream and then analyze them with an external tool. The extracted elementary streams can be further processed, for example, to multiplex new transport streams by means of the Advanced Stream Combiner® (R&S®DV-ASC).

## Summary

The media player and Write to File functions are available to all users of an R&S®DVM50 / DVM100 or DVM400. A free firmware update is offered for devices that have already been supplied. The Software Elementary Stream Analyzer® (R&S®DV-ESA) and the DVB-H time slice analyzer function (part of the option Data Broadcast Analysis R&S®DVM-K11) are available as options.

The streaming interface considerably expands the functions of the R&S®DVM family since it offers detailed analysis of individual transport stream elements or replay of these elements in realtime. The

flexible concept even allows applications such as very computing-time-intensive realtime decoding and replay of HDTV videos on an external PC. Since the R&S®DVM MPEG-2 monitoring system is able to store selected transport stream elements, you can perform further tests with individual analysis tools. These extensions offer utmost flexibility and analysis depth especially for applications in development.

Christian Zühlcke

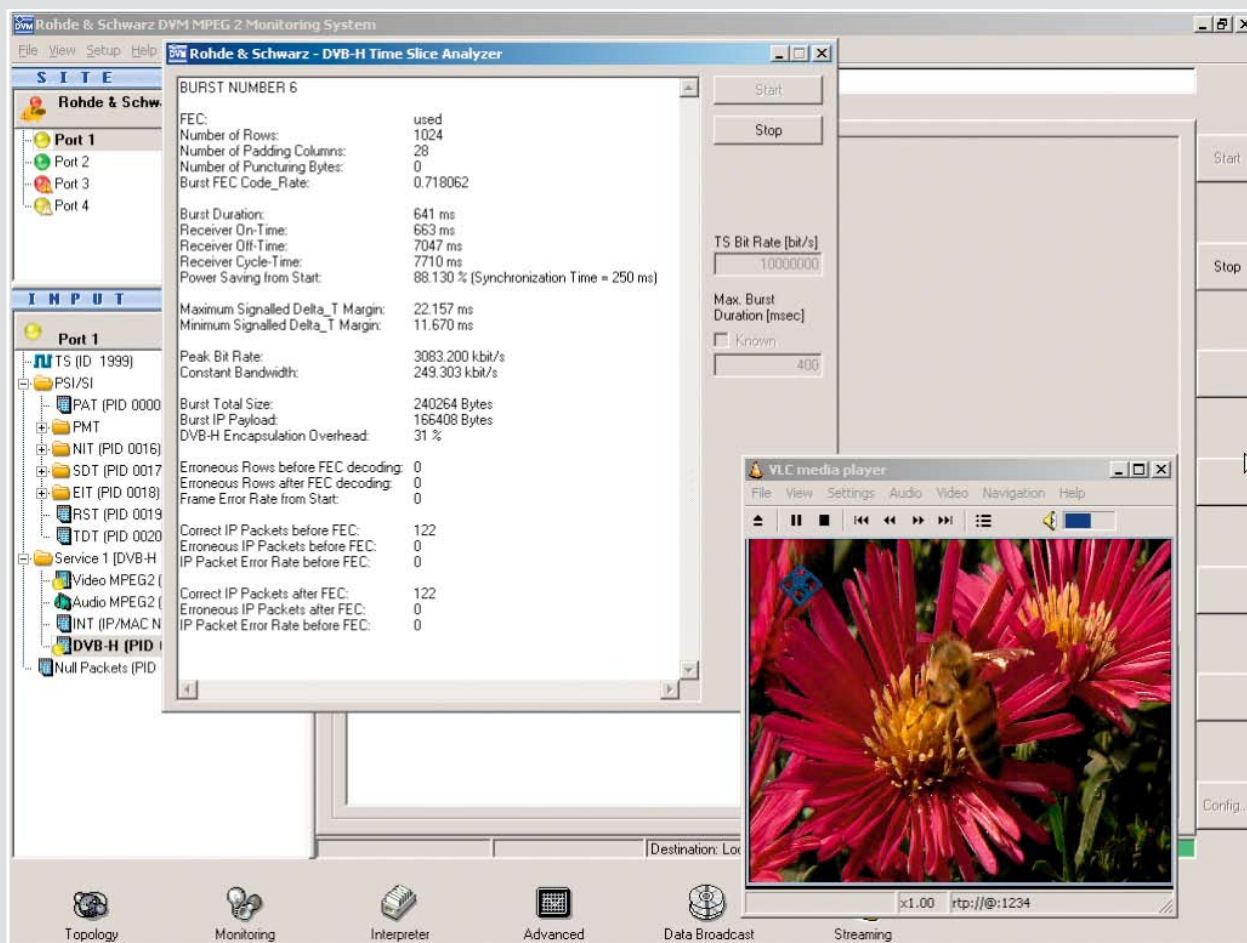

**FIG 3**  
Analysis and replay  
of DVB-H contents by  
means of the DVB-H  
time slice and MPE-  
FEC analyzer.



## TopSec Encryption Units

# Secured communications for global players

**Rohde & Schwarz SIT GmbH addresses**

**the increasing demands for secure communications with an extensive portfolio of encryption units – the TopSec product family. Deployment at international companies is proof of the easy handling and the high level of security these units provide. And Rohde & Schwarz itself is the best example of how to protect electronic communications across a company group against unauthorized access: It is one of the first German companies to secure all corporate communications channels at its headquarters, plants and subsidiaries by means of TopSec encryption solutions.**

## Industrial espionage severely affects companies

Smooth worldwide electronic communications are both a prerequisite and an invaluable competitive edge for the economic success of international companies. However, electronic communications can easily be violated, since phone calls, faxes and e-mails can be intercepted all over the world. Reliable sources estimate that the damage caused by industrial espionage amounts to billions of euros in Germany alone.

To prevent valuable information from falling into wrong hands, organizational, personnel and technical measures are called for. The most down-to-earth technical approach to secure corporate communications (voice, fax and video) is to connect TopSec encryption units in front of the telecommunications systems of each company site (see example on page 55).

## TopSec ensures confidentiality

TopSec encryption units from Rohde & Schwarz (product overview on page 55) have been tried-and-tested and successfully used for many years in diverse security-critical applications in ISDN and GSM networks. This product family provides a high level of security for confidential electronic communications, which is corroborated by TopSec's approval by the German Federal Office for Information Security (BSI) and its extensive use by governmental authorities and major German enterprises.

## How do TopSec units work?

All intra-company voice, fax, video and data connections via the public ISDN in a TopSec-secured infrastructure can be automatically encrypted without any effort on the users' part.

The extremely high standard of the encryption prevents information from being deciphered by unauthorized persons within a realistic time. All TopSec encryption units of a company are centrally administered by the TopSec administrator system. This system ensures that the encryption units of all company sites are furnished with valid certificates for automatic mutual authentication to prevent man in the middle attacks.

Using the TopSec 703+, encrypted voice connections can easily be implemented between staff in the field equipped with the TopSec GSM mobile phone and the company sites. An exception are the sites in North America: These sites need to be integrated into the Euro ISDN encryption by means of the ProCon protocol converter because of differences in the US ISDN standard.

It is also possible to securely communicate with external business partners and customers who also use TopSec encryption units. In this case, all you need to do is dial the appropriate prefix to set up the desired encrypted connection.

## TopSec-secured applications

### Encrypted voice and fax connections

- ◆ Automatically within the company
- ◆ With business partners, use the encryption prefix

More information, data sheets and flyer with product overview at [www.sit.rohde-schwarz.com](http://www.sit.rohde-schwarz.com)



- ▶ ◆ Voice connection to the TopSec GSM mobile phone with encryption prefix

#### Encrypted video conferences

- ◆ Automatic encryption detection within the company
- ◆ With business partners, use the encryption prefix

Video conferences are usually set up using an existing video conference phone book that has incorporated the relevant dialing rules.

#### Encrypted data applications

Applications connected via the telecommunications system can transfer data in encrypted mode to partners equipped with TopSec.

**Encrypted incoming calls** are automatically detected by the TopSec units; incoming calls are accepted once the certificate of the calling partner has

been verified, and switched through to the called party after a key has been negotiated.

#### User-friendly administration

The security and operating parameters of the TopSec encryption devices are administered within a security domain, e. g. within a company, by a TopSec administrator system. The operator installs such a TopSec administrator system for every security domain and equips it with specific, entirely random processes. Each system is therefore unique and is analogous to the trust center of the TopSec security domain. The TopSec units initialized in a domain cannot be administered by another administrator system, not even by an administrator system of the manufacturer.

#### Deployment as easy as possible

The easiest way to implement security requirements is to ensure that users of such systems need not adhere to specific procedures for safeguarding security whenever they use the system – everything relating to security requirements must run automatically.

#### Dial-in lists

Usually the telecommunications systems of a company must allow both plain and encrypted communications connections. Therefore not all channels of the telecommunications system can be reserved exclusively for encrypted operation with TopSec units. Encrypted connections can be automatically set up in the telecommunications system with a TopSec site dial-in list. Such lists can be prepared for specific sites, but also for specific user groups such as corporate management.

#### End-to-end encryption

The site-to-site encryption by connecting TopSec units in front of telecommunications systems ensures high protection of information when it is transmitted via the public ISDN. Within the sites (i.e. on the company premises), however, communication is plain. To protect these communications paths as well, end-to-end encryption units, such as Optiset E privacy modules or DSM fax machines, can be used in addition to the TopSec site-to-site encryption. Moreover, TopSec 703 units for end-to-end encryption can also be installed.

Dr Hartmut Ilse

**Secured communications at Rohde & Schwarz with a Siemens telephone system (front); behind it is the rack with the TopSec 730 encryption units.**



## Overview of TopSec units for securing corporate communications

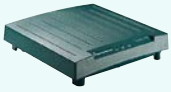

### TopSec 703 and TopSec 703+

Both are encryption units for Euro ISDN basic rate access (BRI). TopSec703+ is also used for encrypting communications with the TopSec GSM mobile phone.

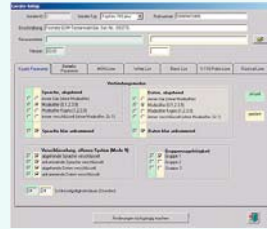

### TopSec Admin

The TopSec administrator system is installed on a PC connected via TopSec 703 to the ISDN. This system manages the security and operating parameters of the TopSec encryption units within a company.

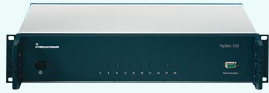

### TopSec 730

Encryption unit for Euro ISDN primary rate access (PRI), which is used to connect larger telecommunications systems to the ISDN, for example.



### ProCon

Protocol converter for converting a maximum of four  $U_{ko}$  connectors of the US ISDN National 1 into maximally four Euro ISDN BRI connectors for connecting up to four TopSec 703 encryption units.



### TopSec GSM

GSM telephone for encrypting GSM and GSM / ISDN voice communications.

## Examples of encrypting all communications of a global player.

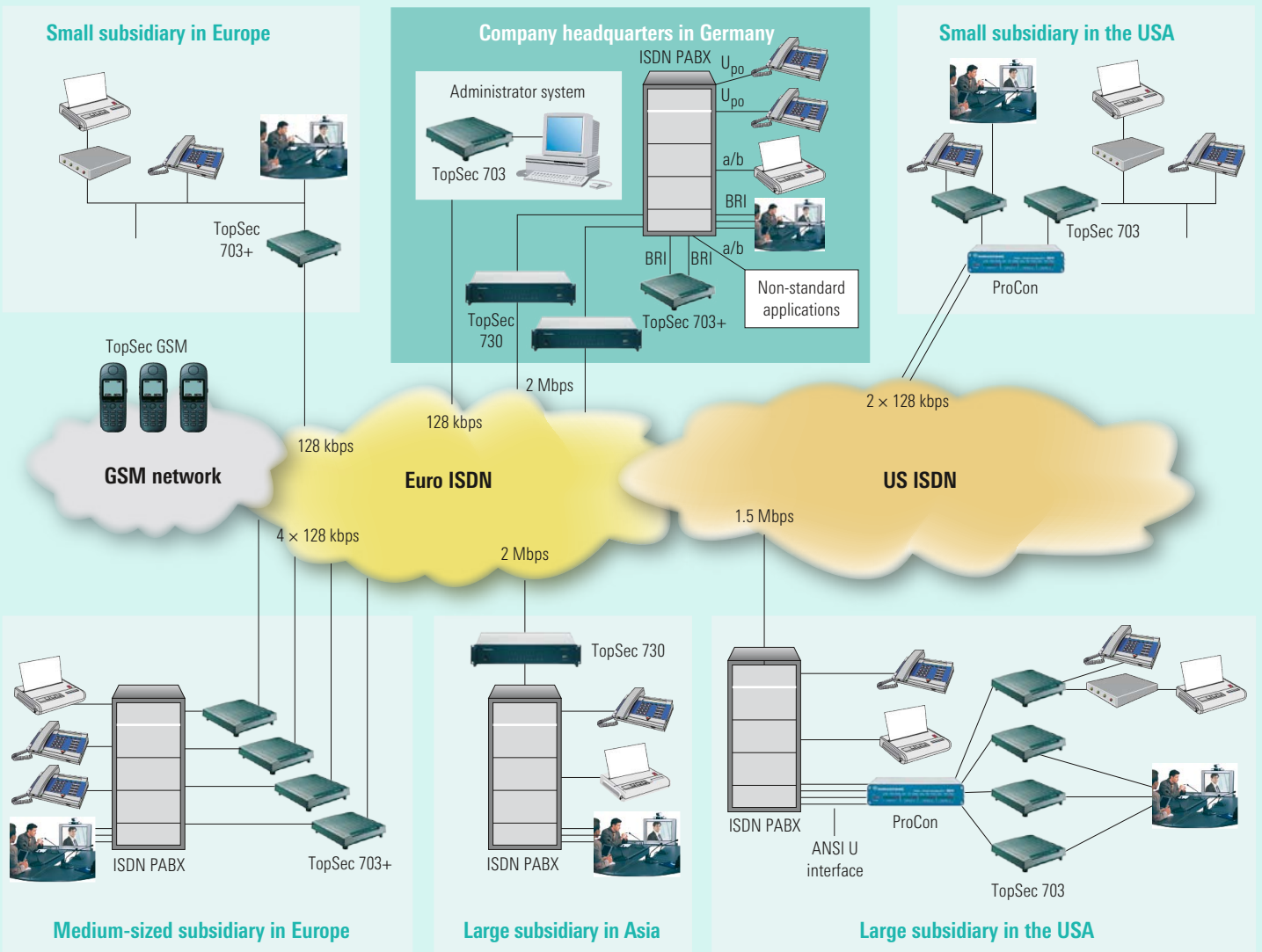

# Civil radiocommunications for Australian air traffic control

**At the end of 2003, NEC Australia Pty Ltd. contracted Rohde & Schwarz to supply over 600 R&S® XU 250A VHF transceivers (FIG 1). Airservices Australia will use these transceivers to modernize the existing air traffic control (ATC) system across Australia as part of the VHF system upgrade project (VHFSUP). What tipped the scale in favor of Rohde & Schwarz was mainly the high performance, reliability and low operating cost of the transceivers.**

## Safety for 11 percent of worldwide airspace

Airservices Australia is responsible for the airspace stretching in latitude from two degrees to 90 degrees south and in longitude from 75 to 163 degrees east. This is equal to 11 percent of the world's total airspace and includes annual monitoring of up to three million domestic and international flights. In the upper airspace, services are also offered for the flight information regions (FIR) of the Solomon Islands and Nauru.

With its two major ATC centers in Brisbane and Melbourne, Australia has two FIRs of its own. These parent centers oversee terminal control units (TCU) in Cairns, Sydney, Adelaide and Perth, which are responsible for ATC within the terminal areas of the largest airports.

TCU	Parent center
Cairns	Brisbane
Sydney	Melbourne
Adelaide	Melbourne
Perth	Melbourne

Communication between the ATC centers and aircraft is carried out via 153 ground stations by using approx. 470 VHF transceivers. The new transceivers will be provided in single-, two- or even three-unit configurations depending on requirements. FIG 2 shows the location of the nationwide stations.

The transceivers have already been delivered and will be installed within the next two years. However, they first had to meet Australian and New Zealand standards. These standards differ from the European standards that were applied in the development of the instruments and are generally implemented when the instruments are used around the world. These standards are also more stringent in certain areas. After a series of further tests verified that the R&S® XU 250A transceivers conformed to these standards, the transceivers can now carry the C-Tick mark, which is similar to the European CE mark.

## Voice switching and communications system

Moreover, a voice switching and communications system (VSCS) from the Frequentis company in Vienna will be supplied for the ATC centers as part of the project. Rohde & Schwarz has already completed several ATC projects together with Frequentis. To ensure that all equipment can be put into operation without any problem, Rohde & Schwarz provided Frequentis with several transceivers for extensive remote-control and monitoring tests.

Dr Rolf Springer





**FIG 1** Instruments of the R&S Series 200 from Rohde & Schwarz are used in 60 countries worldwide. They are implemented in day-to-day operations both by civil and military ATC organizations.

More information on the entire radiocommunications program as well as data sheet for the R&S Series 200 transceivers under [www.rohde-schwarz.com](http://www.rohde-schwarz.com)



R&S Series 200 data sheet

**FIG 2** A lot to do: Vast areas (11 percent of the world's total airspace) and numerous locations characterize the civil radiocommunications network of Australian ATC. It will take approx. two years to equip all locations with the Rohde & Schwarz transceivers.

- Smaller locations with fewer than four transceivers
- Large stations with more than four transceivers

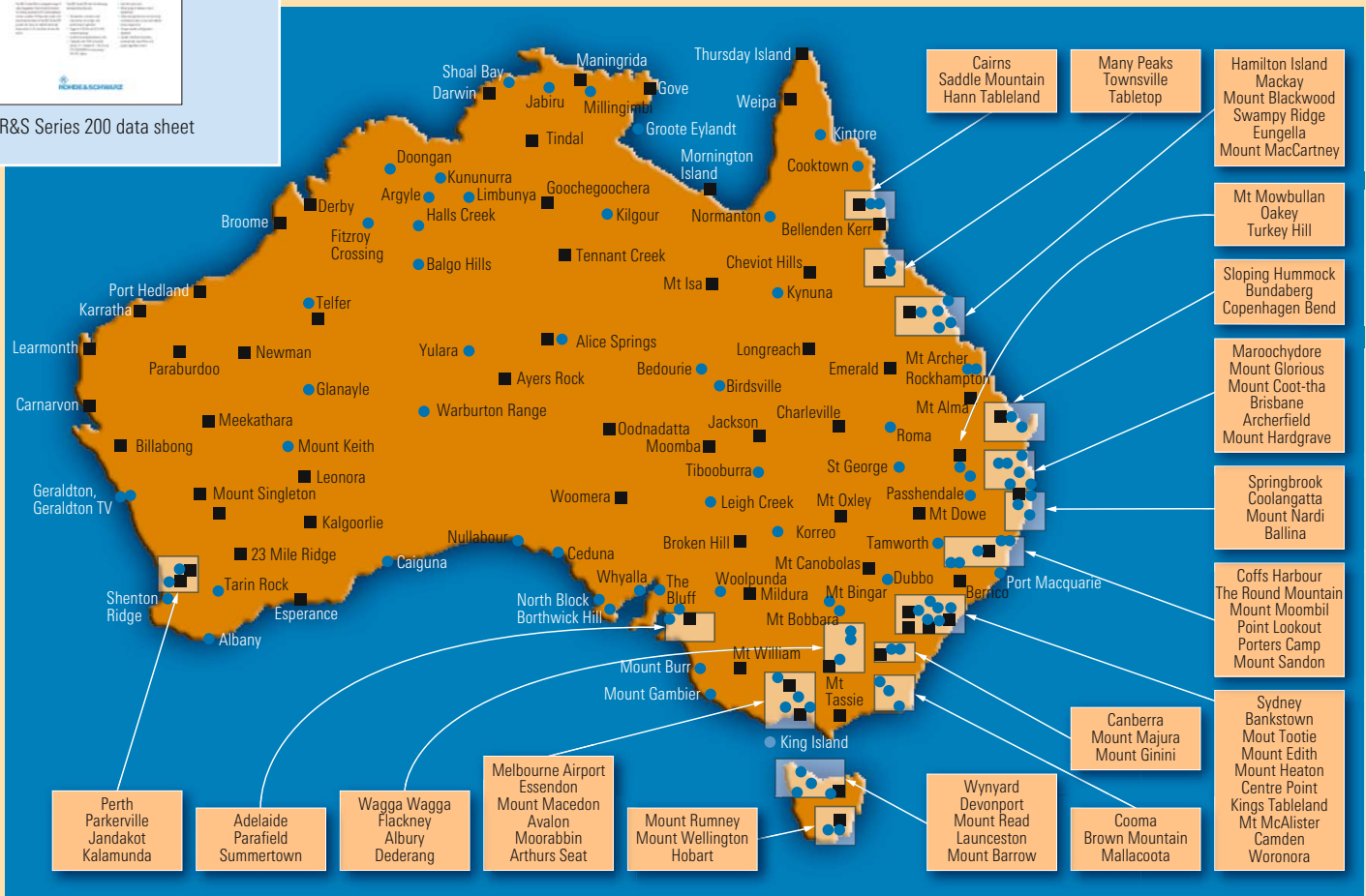



Rohde & Schwarz wins large-scale project in United Arab Emirates

In the following two years, Rohde & Schwarz will modernize the communications system of the Emirates' armed forces. With a volume of more than EUR 100 million, Rohde & Schwarz negotiated the third largest order offered at the IDEX industrial trade fair in Abu Dhabi. During a delegation trip to the Emirates together with the German Chancellor Gerhard Schröder, President and COO Manfred Fleischmann was officially awarded the contract.

German manufacturers such as Rohde & Schwarz attach great importance to the market in the Gulf region. Over the years, the Munich-based company has established close contacts with the United Arab Emirates. In 1993, it set up a service center for maintenance, calibration and repair of T&M and communications equipment. Last year, Rohde & Schwarz also won a large-scale project of strategic importance: the modernization of the entire radiocommunications system of the Emirates' Navy.



President and COO Manfred Fleischmann accepts the order of more than EUR 100 million from Staff Brigadier Obaid Al Kitbi. In the background: General Shaikh Mohammad and German Chancellor Gerhard Schröder.



Photo: Bundespressestelle

Latest generation of airborne transceivers for A400M

Rohde & Schwarz will equip the A400M military transport aircraft with software radios of the R&S®M3AR family.

In January, Rohde & Schwarz concluded a contract as exclusive supplier with EADS-CASA on behalf of the main contractor Airbus Military S.L. The European Organization for Joint Armament Cooperation (OCCAR) will procure 180 A400M aircraft from Airbus Military S.L. by 2022. Since each aircraft will be equipped with four VHF/UHF transceivers, this program is one of the largest military airborne radio projects in this decade.

The OCCAR placed the order with Airbus Military S.L. on behalf of Germany, France, United Kingdom, Spain, Belgium, Luxembourg and Turkey. The first of the 180 planes will be supplied in 2009. Up to 200 further planes are planned. They will be exported to other countries as of 2009.



Copyright: Airbus Military S.L., 2005

Largest European military airborne radio project in this decade: the military transport aircraft A400M will be equipped with software radios from Rohde & Schwarz.

Hameg taken over by Rohde & Schwarz

On April 1, 2005, Rohde & Schwarz took over Hameg GmbH. All jobs as well as the development, production and sales areas will remain intact.

By taking over the Mainhausen-based T&M manufacturer Hameg, Rohde & Schwarz will extend its product portfolio in the lower price segment. For almost 50 years, the name HAMEG has been synonymous with a variety of favorably priced, reliable electronic measuring equipment. Hameg will maintain its brandname as independent subsidiary.

Karl Hartmann, the former owner of the company, is glad to put his life's work in the hands of Rohde & Schwarz: "Rohde & Schwarz personifies the best-owner principle. Consistent corporate policy and sustained know-how will safeguard the future of Hameg." Karl Hartmann sold the company to Rohde & Schwarz for reasons of age.

20 years of successful cooperation with SRMC in China

For more than 20 years, Rohde & Schwarz has had a successful cooperation with the State Radio Monitoring Committee (SRMC) in China in the field of radiomonitoring. This was the reason for sending a delegation of highest-ranking Chinese representatives to Rohde & Schwarz's Munich headquarters.

Director General Mr Zhang from the Ministry of Information Technology in Beijing headed the delegation. For the first time, Director Zhang invited the directors of the most important SRMC provincial authorities in China to pay a visit to Germany.

The SRMC is comparable to the German Regulatory Authority for Post and Telecommunication (RegTP). The SRMC operates a China-wide network of VHF / UHF direction finders to carry out governmental tasks defined within the scope of the International Telecommunication Union (ITU).

German Minister of the Interior, Otto Schily, in Germany's largest science and technology park

**On February 23, 2005, about 500 guests from politics, industry and science came together to attend the annual reception in Germany's largest science and technology park in Berlin-Adlershof. Minister of the Interior Otto Schily was the principal speaker. He praised the competence in crypto technology and thus also paid tribute to Rohde & Schwarz SIT GmbH.**

"Adlershof is excellent proof of the fact that Germany really is a country of ideas", said the minister to his audience of Berlin-based companies. In a private conversation with Henning Krieghoff, President of Rohde & Schwarz SIT GmbH, Otto Schily stressed the Rohde & Schwarz subsidiary's important contribution to national security.

WISTA Management GmbH is the developing and operating company of Adlershof. In addition



**Minister of the Interior Otto Schily during a panel discussion at the annual reception in Germany's largest science and technology park in Berlin-Adlershof. Second on the left: Henning Krieghoff, President of Rohde & Schwarz SIT GmbH.**



Foto: WISTA Management GmbH

tion to Rohde & Schwarz SIT GmbH, more than 370 companies and twelve non-university science institutes work on an area of 4.2 km<sup>2</sup>. The scientific institutes of Humboldt University in Berlin are also included in the science and technology park.

**Rohde & Schwarz SIT GmbH supports "IT security made in Germany"**

**The German Federal Ministry of Economics and Labor, together with companies of the German IT security industry, has launched a joint export initiative called "IT security made in Germany". Rohde & Schwarz SIT GmbH is also part of this new network. The aim of the network is to encourage exports of German IT security solutions and services to specific regions.**

A common name better accentuates the high quality of German products and services in this

market. "This will make countries abroad more aware of Germany's leading role in the field of IT security", says Henning Krieghoff, President of Rohde & Schwarz SIT GmbH. The initiative was launched on March 16, 2005, at an event in the German Federal Ministry of Economics and Labor.

**R&S BICK Mobilfunk presents itself at ZVEI Russia forum**

**Since Russia took part in this year's Hanover trade fair, the Central German Association for Electrical Engineering and Electrical Industry (ZVEI) organized a Russia forum. Experts and representatives of German and Russian companies presented joint projects in the field of communications networks and process, traffic and energy technology. R&S BICK Mobilfunk GmbH presented itself as a specialist for professional mobile radio and as an experienced partner for PMR projects in Russia.**

The Rohde & Schwarz subsidiary together with Sergey Frank from Kienbaum Executive Consultants and Dr Valery Degtyarev, Director General of the Russian company TETRASVYAZ, were invited as representatives for communications networks. Since the mid-90s, R&S BICK Mobilfunk has shown a strong commitment in Russia and has already attained a clear sales success in the field of public security, transport and traffic as well as energy supply. R&S BICK Mobilfunk also intends to participate in TETRARUS, a program to set up a nationwide professional mobile radio network in Russia. This project, under the management of the Russian Ministry for IT and Communications, was presented in detail by Dr Valery Degtyarev at the forum.

**Rohde & Schwarz sponsors EEEfCOM innovation award**



**The EEEfCOM trade show of GEROTRON Communication GmbH will be held from June 29 to 30, 2005, in Ulm, Germany. On this occasion, the EEEfCOM innovation award 2005, sponsored by Rohde & Schwarz among other companies, will be issued.**

The award is intended for scientists and engineers known for their extraordinary work in the field of communications technology. All areas of innovative research and development within information transmission technology and information electronics are covered. Another decisive factor for receiving the award is compatibility for use in practice.

Rohde & Schwarz will present the winner with one of its future-proof instruments from its wide range of test and measurement equipment.

More information at [www.gerotron.de](http://www.gerotron.de)



**ROHDE & SCHWARZ**

[www.rohde-schwarz.com](http://www.rohde-schwarz.com)

**Europe:** [customersupport@rohde-schwarz.com](mailto:customersupport@rohde-schwarz.com) · **North America:** [customer.support@rsa.rohde-schwarz.com](mailto:customer.support@rsa.rohde-schwarz.com) · **Asia:** [customersupport.asia@rohde-schwarz.com](mailto:customersupport.asia@rohde-schwarz.com)